

## AGENDA

Regular Meeting of the  
Nichols Hills Municipal Authority  
Tuesday, April 9, 2024 at 5:30 PM  
City Hall, 6407 Avondale Drive  
Nichols Hills, OK 73116

If special assistance is needed for this meeting by any person wishing to attend, please contact the City Clerk's office no later than 48 hours prior to the meeting, and such assistance will be provided.

Official action may be taken by the Municipal Authority only on items that appear on this Agenda. The Municipal Authority may dispose of the business set out on this Agenda by accepting, approving, adopting, rejecting, amending, or postponing action as to each item, as determined by the Municipal Authority.

1. Call to Order
2. Roll Call
3. Minutes
  - a. Approval of Minutes
4. Total Warrants & Claims
  - a. Consideration of approval, acceptance, rejection, and/or postponement of the following:

<b>Fund</b>	<b>Dollar Amount</b>
i. Nichols Hills Municipal Authority	\$78,924.37

5. Consideration of adoption, approval, acceptance, rejection, amendment, and/or postponement of the following:
  - a. March 2024 Financial Statements
6. Items for Separate Vote - General

- a. Request from the Public Works Department to purchase a Big Tex Deck Equipment trailer for an amount not to exceed \$9,594.40 from Oklahoma State Contract SW-0198, to be paid from NHMA CIP fund.
- b. Request from the Public Works Department to purchase a 2025 Freightliner CNG truck for an amount not to exceed \$164,000.00 from Oklahoma State Contract SW-035T and a Peterson Grapple body for an amount not to exceed \$131,187.00 from Oklahoma State Contract SW-197, to be purchased from the NHMA CIP fund.

7. Adjournment



City Clerk  
City of Nichols Hills, Oklahoma

**MINUTES**

Regular Meeting of the  
Nichols Hills Municipal Authority  
Tuesday, March 12, 2024 at 5:30 PM  
City Hall, 6407 Avondale Drive  
Nichols Hills, OK 73116

- 1. Call to Order
- 2. Roll Call

Attendee Name	Title	Status	Arrived
Sody Clements		Present	
Steven J. Goetzinger		Present	
E. Peter Hoffman		Present	

- 3. Minutes
  - a. February 13, 2024 Minutes

**MOTION:** Goetzinger moved to approve the February 13, 2024 minutes as presented. Hoffman seconded the motion.

<b>RESULT:</b>	<b>APPROVED [UNANIMOUS]</b>
<b>MOVER:</b>	Steven J. Goetzinger
<b>SECONDER:</b>	E. Peter Hoffman
<b>AYES:</b>	Clements, Goetzinger, Hoffman

- 4. Total Warrants and Claims . . . . . \$109,368.47
  - a. Consideration of approval, acceptance, rejection, and/or postponement of the following:

a. Nichols Hills Municipal Authority	\$109,368.47
--------------------------------------	--------------

**MOTION:** Hoffman moved to approve the total warrants and claims as presented. Goetzinger seconded the motion.

**RESULT:**           **APPROVED [UNANIMOUS]**  
**MOVER:**           E. Peter Hoffman  
**SECONDER:**       Steven J. Goetzinger  
**AYES:**             Clements, Goetzinger, Hoffman

5. Consideration of adoption, approval, acceptance, rejection, amendment, and/or postponement of the following:

a. February 2024 Financial Statements

**MOTION:** Goetzinger moved to accept the February 2024 financial statements as presented. Hoffman seconded the motion.

**RESULT:**           **APPROVED [UNANIMOUS]**  
**MOVER:**           Steven J. Goetzinger  
**SECONDER:**       E. Peter Hoffman  
**AYES:**             Clements, Goetzinger, Hoffman

6. Adjournment

**MOTION:** There being no further business, Hoffman moved to adjourn the meeting. Goetzinger seconded the motion.

<b>RESULT:</b>	<b>APPROVED [UNANIMOUS]</b>
<b>MOVER:</b>	E. Peter Hoffman
<b>SECONDER:</b>	Steven J. Goetzinger
<b>AYES:</b>	Clements, Goetzinger, Hoffman

---

Chairman  
Nichols Hills Municipal Authority  
Nichols Hills, Oklahoma

---

General Manager  
Nichols Hills Municipal Authority  
Nichols Hills, Oklahoma

---

Secretary  
Nichols Hills Municipal Authority  
Nichols Hills, Oklahoma

FUND: General Fund

DEPARTMENT	VENDOR NAME	GL ACCOUNT	ACCOUNT DESCRIPTION	DESCRIPTION	AMOUNT
NON-DEPARTMENTAL	OKLAHOMA UNIFORM BUILDING CO	00-32600	Uniform Building Cod	PERMIT FEES MARCH 2024	268.00
				TOTAL:	268.00
Administration	VERIZON WIRELESS	02-84700	Telephone	MONTHLY CHARGES	289.05
	GRANICUS	02-84400	Software Agreements	AGENDA SOFTWARE	412.88
	VISA	02-84300	Training & Membershi	PRE-COUNCIL MEETING	59.70
		02-84300	Training & Membershi	LUNCH MEETING	65.79
		02-84300	Training & Membershi	LUNCH MEETING	64.03
		02-84300	Training & Membershi	LUNCH MEETING	40.27
		02-84300	Training & Membershi	ROTARY CLUB	325.00
	PETTY CASH	02-84300	Training & Membershi	MARCH 2024 RECEIPTS	120.99
	AT&T 831-001-0000 521	02-84700	Telephone	MONTHLY CHARGES	90.48
				TOTAL:	1,468.19
City Attorney	WILLIAMS BOX FORSHEE & BULLA	04-87100	Legal Services	LEGAL SERVICES	25,506.00
				TOTAL:	25,506.00
Municipal Court	OKLAHOMA MUNICIPAL JUDGES AS	05-84300	Training & Membershi	2024-2025 MEMBERSHIP	50.00
	PETTY CASH	05-83000	Material & Supplies	MARCH 2024 RECEIPTS	17.53
	AT&T 831-001-0000 521	05-84700	Telephone	MONTHLY CHARGES	90.48
	OMCCA	05-84300	Training & Membershi	COURT CLERK MEMBERSHIP	55.00
				TOTAL:	213.01
Police Department	COPS PRODUCTS	06-84000	Equipment Maintenanc	BODY ARMOR NIX	812.25
	CASEY NIX	06-84950	EV Charging	HOME CHARGING MAR 2024	27.00
	VERIZON WIRELESS	06-84700	Telephone	MONTHLY CHARGES	727.35
	SHEPHERD AUTOMOTIVE LLC	06-84100	Vehicle Maintenance	OIL CHANGES	70.57
		06-84100	Vehicle Maintenance	OIL CHANGES	70.57
	VISA	06-84300	Training & Membershi	OACP CONFERENCE	399.00
	TRANSUNION RISK AND ALTERNAT	06-84000	Equipment Maintenanc	ACCESS TO DATABASE	100.00
	VISA	06-83000	Material & Supplies	GUN CLEANING SUPPLY	98.89
		06-83000	Material & Supplies	PMAGS	51.96
		06-81200	Medical Exams	MMPI MORALES	125.00
		06-84300	Training & Membershi	OACP CONFERENCE	399.00
		06-83000	Material & Supplies	BUSINESS CARDS	51.98
	DASH MEDICAL GLOVES	06-83000	Material & Supplies	NITRILE GLOVES	138.00
	ASPEN BUILDING SERVICES OF O	06-85000	Janitorial Services	CLEANING SERVICES	1,262.50
	METRO EMERGENCY UPFITTERS	06-83000	Material & Supplies	GOLF CART TAGS	280.00
	AT&T 287288038708	06-84700	Telephone	FIRST NET POLICE	792.83
	AT&T 831-001-0000 521	06-84700	Telephone	MONTHLY CHARGES	361.95
	COOPER AUTO GROUP	06-84100	Vehicle Maintenance	OIL CHANGES	105.21
		06-84100	Vehicle Maintenance	OIL CHANGES	105.21
		06-84100	Vehicle Maintenance	OIL CHANGE	105.21
	DAVID EISCHEID	06-84100	Vehicle Maintenance	MIRROR REPLACEMENT	180.53
	OFFICE DEPOT 35315277	06-83000	Material & Supplies	RECORDS SUPPLIES	217.18
	OG&E	06-84950	EV Charging	MONTHLY CHARGES	64.26
	ONG	06-84800	Utilities	MONTHLY CHARGES	183.20
				TOTAL:	6,729.65
Fire Department	VALVOLINE OIL CHANGE	07-84100	Vehicle Maintenance	OIL CHANGE U-35	85.22
	WAL-MART #9502	07-83000	Material & Supplies	STATION SUPPLIES	205.64
	EMSA	07-85200	EMSA Subsidy	MARCH SUBSIDY 2024	2,557.20
	VERIZON WIRELESS	07-84700	Telephone	MONTHLY CHARGES	194.05
	VISA	07-84300	Training & Membershi	TC: EFO - LODGING	294.00

FUND: General Fund

DEPARTMENT	VENDOR NAME	GL ACCOUNT	ACCOUNT DESCRIPTION	DESCRIPTION	AMOUNT
		07-83000	Material & Supplies	STATION SUPPLIES	130.04
		07-83000	Material & Supplies	STATION SUPPLIES	83.98
		07-84300	Training & Membershi	PIKEPASS	40.00
	ImageNet Consulting, LLC	07-84000	Equipment Maintenanc	CONTRACT INVOICE	26.83
	AT&T 287288038669	07-84700	Telephone	FIRST NET FIRE	185.52
	AT&T 831-001-0000 521	07-84700	Telephone	MONTHLY CHARGES	180.97
	VISA	07-84300	Training & Membershi	COEMA CONF. TRAVEL CLAIM	32.56
		07-84300	Training & Membershi	CHARGES MADE IN ERROR	18.19
	JOSHUA BALCH	07-84300	Training & Membershi	TC: HOSELINE ADVANCE	42.02
		07-84300	Training & Membershi	TRAVEL CLAIM OFFICER 3	31.85
		07-84300	Training & Membershi	TC: FIRE OFFICER III	22.53
	AIR CLEANING TECH INC	07-84200	Building Maintenance	EXHAUST REMOVAL SYSTEM	433.00
	OG&E	07-84800	Utilities	MONTHLY CHARGES	37.25
	ONG	07-84800	Utilities	MONTHLY CHARGES	183.20
	OKLAHOMA STATE UNIVERSITY -	07-84300	Training & Membershi	INST2 CHILL	400.00
	KENNY REYES	07-84300	Training & Membershi	TC: EFO	56.29
				TOTAL:	<u>5,240.34</u>
City Engineer	SMITH ROBERTS BALDISCHWILER	08-86075	Engineering Fees	MONTHLY ENGINEERING	16,505.20
				TOTAL:	<u>16,505.20</u>
Street Department	TRAVIS VOICE & DATA	09-84700	Telephone	MONTHLY CHARGES	25.96
	VALVOLINE OIL CHANGE	09-84100	Vehicle Maintenance	OIL CHANGE	132.30
	WAL-MART #9502	09-83000	Material & Supplies	WATER	41.88
	WESTLAKE HARDWARE	09-83000	Material & Supplies	SUPPLIES	87.96
	VERIZON WIRELESS	09-84700	Telephone	MONTHLY CHARGES	131.01
	NORTHERN SAFETY & INDUSTRIAL	09-83500	Safety Supplies	SAFETY SUPPLY	141.21
	US FLEET TRACKING	09-84100	Vehicle Maintenance	PUBLIC WORKS GPS	149.75
	VISA	09-83500	Safety Supplies	SAFETY APPAREL	166.32
	CINTAS CORP. #064	09-81100	Uniform Allowance	PUBLIC WORKS UNIFORMS	454.97
	CRAFCO INC	09-84000	Equipment Maintenanc	STREET	21.95
		09-83500	Safety Supplies	TRAFFIC CONES	465.50
	MADISON TURF FARMS LLC	09-83000	Material & Supplies	SOD	18.00
	HOLT TRUCK CENTERS	09-84000	Equipment Maintenanc	STREETS SWEEPER	2,272.25
	BLADES GROUP LLC	09-83000	Material & Supplies	ASPHALT	1,804.00
	RED HAWK PRIME LLC	09-83000	Material & Supplies	SHAFT ADAPTER	125.00
	OG&E ELECTRIC SERVICES	09-85500	Street Lighting	STREETLIGHTS	4,468.10
	HASKELL LEMON CONSTRUCTION	09-83000	Material & Supplies	MATERIAL	219.20
		09-83000	Material & Supplies	MATERIAL	183.20
		09-83000	Material & Supplies	MATERIALS	44.00
	HOME DEPOT	09-83000	Material & Supplies	SUPPLIES	88.08
		09-83000	Material & Supplies	SUPPLIES	129.94
		09-83000	Material & Supplies	SUPPLIES	44.35
	SAINTS OCCUPATIONAL HEALTH	09-81200	Medical Exams	DRUG SCREENS	288.00
	OG&E	09-84800	Utilities	MONTHLY CHARGES	143.21
		09-85500	Street Lighting	MONTHLY CHARGES	7,100.15
		09-85500	Street Lighting	MONTHLY CHARGES	30.45
		09-85500	Street Lighting	MONTHLY CHARGES	32.05
		09-85500	Street Lighting	MONTHLY CHARGES	62.63
		09-85500	Street Lighting	MONTHLY CHARGES	31.36
		09-85500	Street Lighting	MONTHLY CHARGES	30.10
		09-85500	Street Lighting	MONTHLY CHARGES	29.63
		09-85500	Street Lighting	MONTHLY CHARGES	30.10
		09-85500	Street Lighting	MONTHLY CHARGES	29.86

FUND: General Fund

DEPARTMENT	VENDOR NAME	GL ACCOUNT	ACCOUNT DESCRIPTION	DESCRIPTION	AMOUNT
	ONG	09-84800	Utilities	MONTHLY CHARGES	73.71
	OREILLY AUTOMOTIVE STORES IN	09-84100	Vehicle Maintenance	SUPPLIES	77.88
		09-84000	Equipment Maintenanc	SUPPLIES	37.28
				TOTAL:	19,211.34
Sanitation	VERIZON WIRELESS	10-84700	Telephone	MONTHLY CHARGES	146.01
	NORTHERN SAFETY & INDUSTRIAL	10-83500	Safety Supplies	SAFETY SUPPLY	282.41
	US FLEET TRACKING	10-84100	Vehicle Maintenance	PUBLIC WORKS GPS	89.85
	VISA	10-83500	Safety Supplies	SAFETY APPAREL	535.43
	CINTAS CORP. #064	10-81100	Uniform Allowance	PUBLIC WORKS UNIFORMS	774.25
	WEX BANK	10-84900	Fuel	FUEL	130.76
		10-84900	Fuel	FUEL	115.55
		10-84900	Fuel	FUEL	111.36
		10-84900	Fuel	ONCUE	96.61
		10-84900	Fuel	CNG	114.82
		10-84900	Fuel	CNG FUEL	115.24
		10-84900	Fuel	CNG FUEL	70.89
		10-84900	Fuel	FUEL	130.14
	REPUBLIC SERVICES	10-85800	Landfill Disposal	COMMERCIAL GARBAGE	73.16
		10-85825	Commercial Garbage D	COMMERCIAL GARBAGE	10,409.87
	SOUTHEAST LANDFILL - 4061	10-85800	Landfill Disposal	MARCH 2024	4,025.72
	OG&E	10-84800	Utilities	MONTHLY CHARGES	143.22
	ONG	10-84800	Utilities	MONTHLY CHARGES	73.71
				TOTAL:	17,439.00
Parks Department	WESTLAKE HARDWARE	11-85700	Parks Maintenance	PARKS	149.97
	VISA	11-85700	Parks Maintenance	SUPPLIES	129.00
		11-85700	Parks Maintenance	SUPPLIES	219.00
	BLUE HOUSE URBAN FARM LLC	11-85700	Parks Maintenance	BUTTERFLY GARDEN	320.00
	FEDERAL CORP	11-85700	Parks Maintenance	MATERIALS	121.14
	IRRIGATION STATION	11-85700	Parks Maintenance	SUPPLIES	10.88
		11-85700	Parks Maintenance	PARTS	22.50
	NORTHWEST LAWN MAINTENANCE I	11-85900	Park Maintenance Con	PARK MAINTENANCE	17,257.50
				TOTAL:	18,229.99
Public Works Admin	TECH-LOCK	12-84200	Building Maintenance	KEYS	3.00
	TRAVIS VOICE & DATA	12-84700	Telephone	MONTHLY CHARGES	69.22
	WAL-MART #9502	12-84300	Training & Membershi	EOM	79.94
	WESTLAKE HARDWARE	12-83000	Material & Supplies	SUPPLIES	9.99
	VERIZON WIRELESS	12-84700	Telephone	MONTHLY CHARGES	167.36
	VISA	12-84300	Training & Membershi	ADOBE RENEWAL	239.88
	TERMINIX PROCESSING CENTER	12-84200	Building Maintenance	PEST CONTROL PW	54.00
		12-84200	Building Maintenance	PEST CONTROL PW	90.00
	ASPEN BUILDING SERVICES OF O	12-85000	Janitorial Services	CLEANING SERVICES	745.00
	AT&T 831-001-0000 521	12-84700	Telephone	MONTHLY CHARGES	45.24
	VISA	12-84200	Building Maintenance	AMAZON	98.72
		12-84200	Building Maintenance	AMAZON	50.07
		12-84200	Building Maintenance	AMAZON	43.93
		12-84300	Training & Membershi	BIRTHDAY	66.36
		12-83000	Material & Supplies	SUPPLIES	97.98
		12-83000	Material & Supplies	SUPPLIES	88.70
		12-83200	Office Supplies	PLANNER	47.99
	DENNIS ALBERT	12-84950	EV Charging	HOME CHARGING MAR 2024	29.56
		12-84950	EV Charging	HOME CHARGING MAR 2024	24.10

FUND: General Fund

DEPARTMENT	VENDOR NAME	GL ACCOUNT	ACCOUNT DESCRIPTION	DESCRIPTION	AMOUNT
		12-84950	EV Charging	DENNIS ALBERT	29.56-
	OK CORPORATION COMM	12-84250	Fueling Station Main	FUEL INSPECTION	50.00
	HOME DEPOT	12-84200	Building Maintenance	KITCHEN REMODEL	307.84
	SAINTS OCCUPATIONAL HEALTH	12-81200	Medical Exams	DRUG SCREENS	96.00
	OFFICE DEPOT 35315277	12-83200	Office Supplies	OFFICE SUPPLIES	23.22
		12-83200	Office Supplies	OFFICE SUPPLIES	203.43
	OG&E	12-84800	Utilities	MONTHLY CHARGES	143.21
	ONG	12-84800	Utilities	MONTHLY CHARGES	73.71
				TOTAL:	<u>2,918.89</u>
General Government	RITE WAY SHREDDING	13-87000	Misc. Expenses	SHREDDING MARCH 2024	104.50
	VISA	13-83000	Material & Supplies	AMAZON	47.57
		13-83000	Material & Supplies	AMAZON	87.84
		13-83000	Material & Supplies	AMAZON	24.49
		13-83000	Material & Supplies	AMAZON	161.98
		13-83000	Material & Supplies	AMAZON	145.12
		13-83000	Material & Supplies	AMAZON	67.08
		13-83000	Material & Supplies	AMAZON	193.02
		13-83000	Material & Supplies	REFUND OF TAXES CHARGED	25.07-
	TERMINIX PROCESSING CENTER	13-84200	Building Maintenance	PEST CONTROL CITY HALL	54.00
	ASPEN BUILDING SERVICES OF O	13-85000	Janitorial Services	CLEANING SERVICES	1,362.50
	VISA	13-83000	Material & Supplies	BIRTHDAY COOKIES	22.81
		13-83000	Material & Supplies	BIRTHDAY SUPPLIES	22.81
		13-83000	Material & Supplies	BIRTHDAY SUPPLIES	2.15
	S & P GLOBAL MARKET INTELLIG	13-87000	Misc. Expenses	CUSIP FEES FOR 2024	91.00
	AT&T 831-001-0000 521	13-84700	Telephone	MONTHLY CHARGES	45.24
	CIVICPLUS LLC	13-87000	Misc. Expenses	ADMIN SUPPORT	299.25
		13-87000	Misc. Expenses	MUNICODE CODIFICATION	7,728.00
	DILLION FREEMAN THOMPSON	13-87200	Education Scholarshi	TUITION REIMBURSEMENT	1,600.00
	EXTREME ANIMALS OF OKLAHOMA	13-87000	Misc. Expenses	CANCELED EVENT	1,150.00-
		13-87000	Misc. Expenses	ARBOR DAY SAFARI TABLE	1,150.00
	EUREKA WATER CO	13-83000	Material & Supplies	TANK RENTAL	22.49
		13-83000	Material & Supplies	5 GAL WATER	136.80
		13-83000	Material & Supplies	5 GAL WATER	136.80
	FRIDAY	13-86300	Publications	NOTICES AND PUBLICATIONS	283.15
		13-86300	Publications	NOTICES AND PUBLICATIONS	742.45
	INSTANT SIGNS INC	13-86300	Publications	OCE BOARDS (5)	272.50
	JOURNAL RECORD PUBLISHING CO	13-86300	Publications	NOTICES AND PUBLICATIONS	31.20
		13-86300	Publications	NOTICES AND PUBLICATIONS	37.95
		13-86300	Publications	NOTICES AND PUBLICATIONS	34.50
		13-86300	Publications	NOTICES AND PUBLICATIONS	37.95
		13-86300	Publications	NOTICES AND PUBLICATIONS	36.90
		13-86300	Publications	NOTICES AND PUBLICATIONS	36.75
		13-86300	Publications	NOTICES AND PUBLICATIONS	37.35
		13-86300	Publications	NOTICES AND PUBLICATIONS	100.20
	OFFICE DEPOT 35315277	13-83000	Material & Supplies	OFFICE SUPPLIES	206.81
	OG&E	13-84800	Utilities	MONTHLY CHARGES	25.23
		13-84800	Utilities	MONTHLY CHARGES	2,356.14
	ONG	13-84800	Utilities	MONTHLY CHARGES	105.93
		13-84800	Utilities	MONTHLY CHARGES	183.20
				TOTAL:	<u>16,858.59</u>
Code Department	TRAVIS VOICE & DATA	14-84700	Telephone	MONTHLY CHARGES	51.92
	VERIZON WIRELESS	14-84700	Telephone	MONTHLY CHARGES	426.80

FUND: General Fund

DEPARTMENT	VENDOR NAME	GL ACCOUNT	ACCOUNT DESCRIPTION	DESCRIPTION	AMOUNT
	US FLEET TRACKING	14-84100	Vehicle Maintenance	PUBLIC WORKS GPS	149.75
	CINTAS CORP. #064	14-81100	Uniform Rental	PUBLIC WORKS UNIFORMS	578.67
	FIRE PROTECTION CONSULTING I	14-88850	Life and Safety	FIRE ALARM PLAN REVIEW	326.48
	CRAFCO INC	14-83500	Safety Supplies	TRAFFIC CONES	294.00
	ANIMAL WELFARE DIVISION	14-85300	Animal Control	ANIMAL WELFARE	185.00
	AT&T 287307218639	14-84700	Telephone	MONTHLY CHARGES	94.36
	VISA	14-83000	Material & Supplies	BROCHURES	72.97
		14-85300	Animal Control	ACE WEST LAKE	17.20
		14-83200	Office Supplies	OFFICE SUPPLIES	21.59
		14-84300	Training & Membershi	STUDY GUIDE	79.00
	VISA	14-84300	Training & Membershi	CODE TRAINING	60.80
	T-MOBILE USA INC	14-84100	Vehicle Maintenance	TRACKERS GPS	14.00
	TYLER TECHNOLOGIES INC	14-84400	Software Agreement	CODE MODULE TRAINING	580.00
	OG&E	14-84800	Utilities	MONTHLY CHARGES	143.21
	ONG	14-84800	Utilities	MONTHLY CHARGES	73.71
				TOTAL:	<u>3,169.46</u>
Risk Manager	WAL-MART #9502	15-84300	Training & Membershi	SUPPLIES	18.63
	VERIZON WIRELESS	15-84700	Telephone	MONTHLY CHARGES	43.67
	VISA	15-84300	Training & Membershi	GUY'S	20.50
		15-84300	Training & Membershi	LOVES	24.63
		15-84300	Training & Membershi	DUNKIN DONUTS	35.81
		15-84300	Training & Membershi	PRIMA MEMBERSHIP	425.00
	AT&T 831-001-0000 521	15-84700	Telephone	MONTHLY CHARGES	45.24
				TOTAL:	<u>613.48</u>
Information Systems Mg	UNITED ENGINES	16-84000	Equipment Maintenanc	GENERATOR SERVICE CALL	371.25
	COX COMMUNICATIONS	16-84600	Lease/Rental	PUBLIC WORKS INTERNET	267.00
		16-84600	Lease/Rental	CITY HALL INTERNET	1,146.99
	VERIZON WIRELESS	16-84700	Telephone	MONTHLY CHARGES	249.03
	FORD AUDIO-VIDEO SYSTEMS LLC	16-84300	Training & Membershi	SERVER MIGRATION ASSIST	1,400.00
	VISA	16-84000	Equipment Maintenanc	DOMAIN LICENSE RENEWAL	100.34
		16-84000	Equipment Maintenanc	NICHOLSHILL.TV PRIVIATE	41.97
		16-84000	Equipment Maintenanc	NETWORK SECURITY DEVICE	180.00
		16-84000	Equipment Maintenanc	ONLINE BACKUP RENEWAL	99.50
		16-84000	Equipment Maintenanc	SECURITY CERT RENEWAL	175.50
		16-84000	Equipment Maintenanc	FOREIGN FEE FOR SSI2BUY	3.51
		16-84000	Equipment Maintenanc	ADOBE PRO LICENSE	222.60
		16-84000	Equipment Maintenanc	QR CODE GENERATOR LICENSE	150.00
		16-84000	Equipment Maintenanc	QR CODE GENERATOR LICENSE	18.79
		16-84000	Equipment Maintenanc	BLUETOOTH DEVICES FOR FD	103.90
	ZOHO CORPORATION	16-84000	Equipment Maintenanc	SECURITY SOFTWARE RENEWAL	4,421.00
	AT&T 831-001-0000 521	16-84700	Telephone	MONTHLY CHARGES	45.24
	DAVID STOOPS ELECTRIC	16-84200	Building Maintenance	EXHAUST FAN FOR FIRE DP	654.60
	PROJECT A INC	16-84000	Equipment Maintenanc	WEB HOSTING RENEWAL	150.00
				TOTAL:	<u>9,801.22</u>

FUND: Municipal Authority

DEPARTMENT	VENDOR NAME	GL ACCOUNT	ACCOUNT DESCRIPTION	DESCRIPTION	AMOUNT
NON-DEPARTMENTAL	MISC VENDOR	HARRISON, VI 00-34150	Utility Refunds	02-00729-16	141.36
		HASSAN, SAME 00-34150	Utility Refunds	02-00847-08	45.79
				TOTAL:	187.15
Municipal Authority	TRAVIS VOICE & DATA	12-84700	Telephone	MONTHLY CHARGES	25.96
	VALVOLINE OIL CHANGE	12-84100	Vehicle Maintenance	OIL CHANGE	102.82
	WAL-MART #9502	12-83000	Materials & Supplies	WATER	41.88
	WESTLAKE HARDWARE	12-83000	Materials & Supplies	PARKS	7.28
	BRITTON WELDING & AUTO	12-83000	Materials & Supplies	WATER	40.00
	P & K EQUIPMENT	12-84000	Equipment Maintenanc	WELLS MOWER	277.34
	TPSI	12-84950	Printing & Processin	UTILITY LATE NOTICES	84.08
		12-84950	Printing & Processin	UTILITY INVOICES MARCH 24	1,945.00
	ACCURATE ENVIRONMENT	12-84550	Water Quality Testin	WATER TESTING	30.00
		12-84550	Water Quality Testin	WATER TESTING	30.00
		12-84550	Water Quality Testin	WATER TESTING	120.00
		12-83400	Lab Chemicals	CHEMICALS	130.90
		12-84550	Water Quality Testin	ACCURATE	85.25
	VERIZON WIRELESS	12-84700	Telephone	MONTHLY CHARGES	819.48
	NORTHERN SAFETY & INDUSTRIAL	12-83500	Safety Supplies	SAFETY SUPPLY	141.21
	UTILITY TECHNOLOGY SERVICES	12-83000	Materials & Supplies	METER	1,140.00
	US FLEET TRACKING	12-84100	Vehicle Maintenance	PUBLIC WORKS GPS	269.55
	VISA	12-83500	Safety Supplies	SAFETY APPAREL	369.11
	LAMPTON WELDING SUPPLY CO IN	12-84600	Equipment Rental	RENTAL	84.95
		12-84600	Equipment Rental	LEASE/RENTAL	169.90
	SHERWIN-WILLIAMS CO	12-83000	Materials & Supplies	SUPPLIES	479.63
	CINTAS CORP. #064	12-81100	Uniform Rental	PUBLIC WORKS UNIFORMS	653.74
	CITY OF OKLAHOMA CITY	12-87700	OKC Sewer Charges	MONTHLY CHARGES	50,144.43
	CRAFCO INC	12-83500	Safety Supplies	TRAFFIC CONES	465.50
	PETTY CASH	12-84100	Vehicle Maintenance	MARCH 2024 RECEIPTS	44.50
	AT&T 287307218639	12-84700	Telephone	FIRST NET PUBLIC WORKS	1,167.16
	TOTAL EQUIPMENT & RENTAL OF	12-84000	Equipment Maintenanc	DIGGER	1,424.00
	MADISON TURF FARMS LLC	12-83000	Materials & Supplies	SOD	64.00
	WATER TECH INC.	12-83400	Lab Chemicals	CHLORINE FOR WELLS	1,048.00
	PRAIRIE DIRT SOLUTIONS	12-83000	Materials & Supplies	TOP SOIL	696.00
	VISA	12-84300	Training & Membershi	WELLS	300.00
		12-84300	Training & Membershi	OWRB EGOV CHARGE	8.80
		12-83000	Materials & Supplies	AMAZON	139.99
		12-84100	Vehicle Maintenance	DISCOUNT TIRE	186.00
		12-83700	Misc Supplies	SUPPLIES	13.79
		12-83000	Materials & Supplies	PARTS FOR TRUCK	70.74
	T-MOBILE USA INC	12-84100	Vehicle Maintenance	TRACKERS GPS	28.00
	HOME DEPOT	12-83000	Materials & Supplies	SUPPLIES	71.92
		12-83000	Materials & Supplies	SUPPLIES	88.08
		12-83000	Materials & Supplies	SUPPLIES	149.94
	INTERSTATE BATTERY SUPPLY	12-83000	Materials & Supplies	BATTERY	145.95
	SAINTS OCCUPATIONAL HEALTH	12-81200	Medical Exams	DRUG SCREENS	288.00
	OG&E	12-84800	Utilities	MONTHLY CHARGES	143.22
		12-84800	Utilities	MONTHLY CHARGES	3,523.06
		12-84800	Utilities	MONTHLY CHARGES	166.63
		12-84800	Utilities	MONTHLY CHARGES	1,293.46
		12-84800	Utilities	MONTHLY CHARGES	7,008.47
		12-84800	Utilities	MONTHLY CHARGES	143.42
		12-84800	Utilities	MONTHLY CHARGES	1,245.60
	OK CONTRACTORS SUPPLY	12-83000	Materials & Supplies	SUPPLIES WATER	665.00

FUND: Municipal Authority

DEPARTMENT	VENDOR NAME	GL ACCOUNT	ACCOUNT DESCRIPTION	DESCRIPTION	AMOUNT
	ONG	12-84800	Utilities	MONTHLY CHARGES	169.76
		12-84800	Utilities	MONTHLY CHARGES	169.76
		12-84800	Utilities	MONTHLY CHARGES	248.03
		12-84800	Utilities	MONTHLY CHARGES	169.76
		12-84800	Utilities	MONTHLY CHARGES	73.70
	OREILLY AUTOMOTIVE STORES IN	12-83000	Materials & Supplies	SUPPLIES	45.27
		12-83000	Materials & Supplies	SUPPLIES	12.30
		12-84000	Equipment Maintenanc	SUPPLIES	66.90
				TOTAL:	<u>78,737.22</u>

FUND: General Fund - CIP

DEPARTMENT	VENDOR NAME	GL ACCOUNT	ACCOUNT DESCRIPTION	DESCRIPTION	AMOUNT
Sanitation	PREMIER TRUCK GROUP	10-88100	Capital Imp - Vehicl	SANITATION TRUCK	151,000.00
				TOTAL:	151,000.00

FUND: Designated Funds-Par

DEPARTMENT	VENDOR NAME	GL ACCOUNT	ACCOUNT DESCRIPTION	DESCRIPTION	AMOUNT
Parks Department	HOWARD-FAIRBAIRN SITE DESIGN	11-88600	Redbud Park	REDBUD PARK DESIGN	20,750.00
		11-88600	Redbud Park	REDBUD PARK DESIGN	15,000.00
	VALBRIDGE PROPERTY ADVISORS	11-88500	Capital Outlay - War	APPRAISAL 1842 WESTMINSTE	<u>2,400.00</u>
				TOTAL:	38,150.00

FUND: General Obligation B

DEPARTMENT	VENDOR NAME	GL ACCOUNT	ACCOUNT DESCRIPTION	DESCRIPTION	AMOUNT
2020 GO Bond	LANELIGHT TRAFFIC TECHNOLOGI	90-98950	Traffic Controls	TRAFFIC LIGHTS	21,026.72
	LUTHER SIGN CO	90-98950	Traffic Controls	DIRECTION SIGN	862.68
	TOTAL:				21,889.40
2021 GO Bond	SMITH ROBERTS BALDISCHWILER	91-98550	Water Projects	WC-2101 Water Treatment	5,451.00
	LANDMARK CONSTRUCTION GROUP,	91-98550	Water Projects	WC-2101	866,020.00
	EDWARDS EQUIPMENT LLC	91-98550	Water Projects	EQUIPMENT	23,642.00
TOTAL:				895,113.00	
2022 GO Bond	SMITH ROBERTS BALDISCHWILER	92-97550	Paving Projects	PC-2301 RANDEL PAVING	13,922.53
		92-98750	Sanitary Sewer Proje	SC-2401 SANITARY SEWER	10,924.88
	SOUTHWEST WATER WORKS LLC	92-98750	Sanitary Sewer Proje	SEWER LINE	47,740.58
	DAVENPORT GROUP	92-99450	Technology	EXPAND BACKUP STORAGE	10,529.00
	CIVICPLUS LLC	92-99450	Technology	WEBSITE DOMAIN	83.78
		92-99450	Technology	OPTIMIZE FORM BUILDING	1,868.73
	LANDMARK CONSTRUCTION GROUP,	92-99800	Expenses paid from I	FIRE TOWER	231,111.49
		92-99800	Expenses paid from I	FIRE TOWER	14,295.67
		92-99700	Fire Projects	FIRE TOWER	16,532.71
	TOTAL:				347,009.37
	2023 GO BOND	SMITH ROBERTS BALDISCHWILER	93-97550	Paving Projects	PC-2401 6600-6800 E GRAND
		93-97550	Paving Projects	PC-2302 ENGINEERING	1,565.49
		93-99800	Other expenses paid	MISC GO BOND EXPENSE	737.74
LANDMARK CONSTRUCTION GROUP,		93-99700	Fire Projects	FIRE TOWER	64,948.80
		93-99700	Fire Projects	FIRE TOWER	241,813.92
		93-99800	Other expenses paid	FIRE TOWER	140,956.20
ECS SOUTHWEST LLP		93-97550	Paving Projects	TESTING RANDEL ROAD	1,530.25
RUDY CONSTRUCTION CO.		93-97550	Paving Projects	PC-2301 RANDEL ROAD	162,212.74
TOTAL:				633,305.94	

===== FUND TOTALS =====

01	General Fund	144,172.36
06	Municipal Authority	78,924.37
07	General Fund - CIP	151,000.00
20	Designated Funds-Parks	38,150.00
80	General Obligation Bonds	1,897,317.71
-----		
GRAND TOTAL:		2,309,564.44
-----		

TOTAL PAGES: 10

SELECTION CRITERIA

-----  
SELECTION OPTIONS

VENDOR SET: 01-City of Nichols Hills  
VENDOR: Exclude: 01-1012, 01-1090, 01-1095, 01-1130, 01-1398, 01-1433, 01-1845, 01-1958, 01-1968, 01-2006  
CLASSIFICATION: All  
BANK CODE: Exclude: PY  
ITEM DATE: 3/01/2024 THRU 3/31/2024  
ITEM AMOUNT: 99,999,999.00CR THRU 99,999,999.00  
GL POST DATE: 0/00/0000 THRU 99/99/9999  
CHECK DATE: 0/00/0000 THRU 99/99/9999

-----  
PAYROLL SELECTION

PAYROLL EXPENSES: NO  
EXPENSE TYPE: N/A  
CHECK DATE: 0/00/0000 THRU 99/99/9999

-----  
PRINT OPTIONS

PRINT DATE: None  
SEQUENCE: By Department  
DESCRIPTION: Distribution  
GL ACCTS: YES  
REPORT TITLE: C L A I M S L I S T  
SIGNATURE LINES: 0

-----  
PACKET OPTIONS

INCLUDE REFUNDS: YES  
INCLUDE OPEN ITEM:NO  
-----

06 -Municipal Authority

ACCOUNT #	ACCOUNT DESCRIPTION	BALANCE
<b>ASSETS</b>		
=====		
06-00-10099	Claim on Cash	1,417,405.40
06-00-11000	T-Bills and CD's	1,400,000.00
06-00-11100	Interest Receivable	39,160.58
06-00-12150	Utility Receivable	393,172.25
06-00-13900	Unbilled Receivable	162,705.00
06-00-14800	Allowance for Doubtful Account	( 26,586.93)
06-00-14850	Bad Debt Receivable	28,585.83
06-00-15000	Deferred outflow of resources	374,590.00
06-00-15500	Deferred Outflow - OPEB	43,637.00
06-00-20000	Fixed Assets	47,398,596.03
06-00-20100	Accumulated Depreciation	( 30,746,611.89)
06-00-21000	Land	207,742.00
06-00-21500	Construction in Progress	<u>1,817,431.06</u>
		<u>22,509,826.33</u>
TOTAL ASSETS		22,509,826.33
		=====
<b>LIABILITIES</b>		
=====		
06-00-30090	Payable - Collection AgencyFee	5,735.02
06-00-30099	A/P Due to Pooled Cash	78,863.52
06-00-31800	Comp Absent Payable	5,383.02
06-00-31890	Compensated Absences - Long Te	48,447.00
06-00-34000	City of NH - Garbage	86,069.81
06-00-34100	Unearned Rev (Unapplied Credit	15,987.34
06-00-34325	Deposit - Fire Hydrant Meter	5,200.00
06-00-34500	Due to Tyler Tech (Cr Cd Fees)	1,547.25
06-00-34900	Notes Payable - Current Portio	899.00
06-00-35000	NOTES PAYABLE	14,404.00
06-00-38000	Deferred inflow of resources	38,888.00
06-00-38500	Deferred Inflow - OPEB	50,180.00
06-00-40000	Net Pension Liability	20,673.00
06-00-40100	OPEB Liability	<u>98,791.00</u>
TOTAL LIABILITIES		<u>471,067.96</u>
<b>EQUITY</b>		
=====		
06-00-50400	Net Investment-Capital Assets	18,419,867.00
06-00-52090	Unrestricted Fund Balance	<u>3,411,673.40</u>
TOTAL BEGINNING EQUITY		21,831,540.40
TOTAL REVENUE		3,967,907.27
TOTAL EXPENDITURES		<u>3,760,689.30</u>
TOTAL REVENUE OVER/(UNDER) EXPENSES		207,217.97
TOTAL EQUITY & REV. OVER/(UNDER) EXP.		<u>22,038,758.37</u>
TOTAL LIABILITIES, EQUITY & REV.OVER/(UNDER) EXP.		22,509,826.33
		=====

13 -Municipal Authority - CIP

ACCOUNT #	ACCOUNT DESCRIPTION	BALANCE	
<b>ASSETS</b>			
=====			
13-00-10099	Claim on Cash	202,715.76	
13-00-11000	T-Bills and CD's	1,100,000.00	
13-00-11100	Interest Receivable	<u>10,150.99</u>	
			<u>1,312,866.75</u>
TOTAL ASSETS			1,312,866.75
=====			
<b>LIABILITIES</b>			
=====			
13-00-37176	Retainage Payable	<u>76,149.00</u>	
TOTAL LIABILITIES			<u>76,149.00</u>
<b>EQUITY</b>			
=====			
13-00-57100	Fund Bal-Capital Improvements	<u>1,367,709.73</u>	
TOTAL BEGINNING EQUITY			1,367,709.73
TOTAL REVENUE			96,427.99
TOTAL EXPENDITURES		<u>227,419.97</u>	
TOTAL REVENUE OVER/(UNDER) EXPENSES		( 130,991.98)	
TOTAL EQUITY & REV. OVER/(UNDER) EXP.			<u>1,236,717.75</u>
TOTAL LIABILITIES, EQUITY & REV.OVER/(UNDER) EXP.			1,312,866.75
=====			

CITY OF NICHOLS HILLS  
 REVENUE & EXPENSE REPORT (UNAUDITED)  
 AS OF: MARCH 31ST, 2024

06 -Municipal Authority  
 FINANCIAL SUMMARY

% OF YEAR COMPLETED: 75.00

	CURRENT BUDGET	CURRENT PERIOD	YEAR TO DATE ACTUAL	TOTAL ENCUMBERED	BUDGET BALANCE	% BUDGET REMAINING
<u>REVENUE SUMMARY</u>						
Municipal Auth Revenue	<u>5,068,961</u>	<u>318,298.21</u>	<u>3,967,907.27</u>	<u>0.00</u>	<u>1,101,053.75</u>	<u>21.72</u>
TOTAL REVENUES	5,068,961	318,298.21	3,967,907.27	0.00	1,101,053.75	21.72
<u>EXPENDITURE SUMMARY</u>						
Municipal Authority	<u>5,068,959</u>	<u>369,004.66</u>	<u>3,760,689.30</u>	<u>2,649.17</u>	<u>1,305,620.55</u>	<u>25.76</u>
TOTAL EXPENDITURES	5,068,959	369,004.66	3,760,689.30	2,649.17	1,305,620.55	25.76
REVENUE OVER/ (UNDER) EXPENDITURES		2 ( 50,706.45)	207,217.97 (	2,649.17) (	204,566.80)	8,340.00-

06 -Municipal Authority

% OF YEAR COMPLETED: 75.00

REVENUES	CURRENT BUDGET	CURRENT PERIOD	YEAR TO DATE ACTUAL	TOTAL ENCUMBERED	BUDGET BALANCE	% BUDGET REMAINING
<b>Municipal Auth Revenue</b>						
<b>Water</b>						
06-00-75300 Water Revenue	3,529,874	208,964.80	2,730,932.73	0.00	798,941.27	22.63
TOTAL Water	3,529,874	208,964.80	2,730,932.73	0.00	798,941.27	22.63
<b>Wastewater</b>						
06-00-75700 Sewer Revenue	330,116	26,063.89	266,715.88	0.00	63,400.12	19.21
06-00-75800 OKC Sewer Charges Revenue	1,055,208	73,316.76	820,682.49	0.00	234,525.51	22.23
TOTAL Wastewater	1,385,324	99,380.65	1,087,398.37	0.00	297,925.63	21.51
<b>Water Taps</b>						
06-00-75900 Water Tap Revenue	33,596	3,265.00	20,773.00	0.00	12,823.00	38.17
TOTAL Water Taps	33,596	3,265.00	20,773.00	0.00	12,823.00	38.17
<b>Fines &amp; Forfeits</b>						
06-00-76000 MXU Installation	320	0.00	0.00	0.00	320.00	100.00
TOTAL Fines & Forfeits	320	0.00	0.00	0.00	320.00	100.00
<b>Penalties</b>						
06-00-77750 Penalty Charges	19,270	512.02	11,575.29	0.00	7,694.71	39.93
TOTAL Penalties	19,270	512.02	11,575.29	0.00	7,694.71	39.93
<b>Investment Earnings</b>						
06-00-78200 Interest Income	65,133	6,050.74	115,852.88	0.00	(50,719.88)	77.87-
TOTAL Investment Earnings	65,133	6,050.74	115,852.88	0.00	(50,719.88)	77.87-
<b>Miscellaneous Revenue</b>						
06-00-79100 Misc Income	2,776	125.00	1,375.00	0.00	1,401.00	50.47
TOTAL Miscellaneous Revenue	2,776	125.00	1,375.00	0.00	1,401.00	50.47
<b>Fund Balance Carryover</b>						
06-00-79800 Carryover	32,668	0.00	0.00	0.00	32,668.02	100.00
TOTAL Fund Balance Carryover	32,668	0.00	0.00	0.00	32,668.02	100.00
TOTAL Municipal Auth Revenue	5,068,961	318,298.21	3,967,907.27	0.00	1,101,053.75	21.72
TOTAL REVENUE	5,068,961	318,298.21	3,967,907.27	0.00	1,101,053.75	21.72

06 -Municipal Authority

% OF YEAR COMPLETED: 75.00

DEPARTMENTAL EXPENDITURES	CURRENT BUDGET	CURRENT PERIOD	YEAR TO DATE ACTUAL	TOTAL ENCUMBERED	BUDGET BALANCE	% BUDGET REMAINING
---------------------------	----------------	----------------	---------------------	------------------	----------------	--------------------

Mun Auth Engineering  
 =====

Other Services

Municipal Authority  
 =====

Personnel Services

06-12-80100 Salary	728,036	53,584.72	507,456.92	0.00	220,579.40	30.30
06-12-80200 Overtime	8,600	170.21	11,492.24	0.00 (	2,892.24)	33.63-
06-12-80300 FICA/Medicare	55,854	4,168.89	40,174.83	0.00	15,679.09	28.07
06-12-80400 Dental Insurance	5,581	465.12	4,186.08	0.00	1,394.92	24.99
06-12-80500 Health Insurance	91,200	8,424.87	74,711.73	0.00	16,488.27	18.08
06-12-80600 Workers Comp	22,490	0.00	20,369.36	0.00	2,120.64	9.43
06-12-80700 Unemployment	2,704	0.00	931.69	0.00	1,772.31	65.54
06-12-80800 OMRP Pension	56,858	4,354.38	41,731.93	0.00	15,125.85	26.60
06-12-80900 Stand by Pay	9,300	675.00	5,625.00	0.00	3,675.00	39.52
06-12-81100 Uniform Rental	6,300	653.74	6,140.76	0.00	159.24	2.53
06-12-81200 Medical Exams	<u>500</u>	<u>288.00</u>	<u>345.76</u>	<u>0.00</u>	<u>154.24</u>	<u>30.85</u>
TOTAL Personnel Services	987,423	72,784.93	713,166.30	0.00	274,256.72	27.77

Material and Supplies

06-12-83000 Materials & Supplies	45,000	3,857.98	82,341.91	1,381.00 (	38,722.91)	86.05-
06-12-83200 Office Supplies	2,200	0.00	1,190.57	0.00	1,009.43	45.88
06-12-83300 Minor Tools	2,000	0.00	209.90	0.00	1,790.10	89.51
06-12-83400 Lab Chemicals	4,200	1,178.90	4,998.06	0.00 (	798.06)	19.00-
06-12-83500 Safety Supplies	3,200	975.82	2,152.37	0.00	1,047.63	32.74
06-12-83700 Misc Supplies	<u>500</u>	<u>13.79</u>	<u>36.86</u>	<u>0.00</u>	<u>463.14</u>	<u>92.63</u>
TOTAL Material and Supplies	57,100	6,026.49	90,929.67	1,381.00 (	35,210.67)	61.66-

Other Services

06-12-84000 Equipment Maintenance	10,000	1,768.24	24,909.18	0.00 (	14,909.18)	149.09-
06-12-84100 Vehicle Maintenance	15,000	630.87	14,268.96	1,182.92 (	451.88)	3.01-
06-12-84300 Training & Membership	8,000	308.80	9,299.70	0.00 (	1,299.70)	16.25-
06-12-84400 Software Agreements	17,850	0.00	10,086.19	0.00	7,763.81	43.49
06-12-84500 Well Maintenance	60,000	0.00	37,650.24	0.00	22,349.76	37.25
06-12-84550 Water Quality Testing	18,000	265.25	7,449.30	85.25	10,465.45	58.14
06-12-84600 Equipment Rental	2,000	254.85	693.25	0.00	1,306.75	65.34
06-12-84650 Lease Agreements	73,650	0.00	45,040.52	0.00	28,609.48	38.85
06-12-84700 Telephone	24,558	2,012.60	18,097.50	0.00	6,460.50	26.31
06-12-84800 Utilities	305,681	14,354.87	211,339.45	0.00	94,341.55	30.86
06-12-84900 Fuel	42,606	0.00	16,370.15	0.00	26,235.85	61.58
06-12-84950 Printing & Processing - Uti	16,000	2,029.08	13,451.21	0.00	2,548.79	15.93
06-12-85350 Emergency Repairs	5,000	0.00	0.00	0.00	5,000.00	100.00
06-12-86400 Auditing Fees	30,000	0.00	21,007.56	0.00	8,992.44	29.97
06-12-87700 OKC Sewer Charges	775,000	50,144.43	561,111.87	0.00	213,888.13	27.60

CITY OF NICHOLS HILLS  
 REVENUE & EXPENSE REPORT (UNAUDITED)  
 AS OF: MARCH 31ST, 2024

06 -Municipal Authority

% OF YEAR COMPLETED: 75.00

DEPARTMENTAL EXPENDITURES	CURRENT BUDGET	CURRENT PERIOD	YEAR TO DATE ACTUAL	TOTAL ENCUMBERED	BUDGET BALANCE	% BUDGET REMAINING
06-12-87800 Leasehold Transfer	<u>2,534,255</u>	<u>211,187.92</u>	<u>1,900,691.28</u>	<u>0.00</u>	<u>633,563.72</u>	<u>25.00</u>
TOTAL Other Services	3,937,600	282,956.91	2,891,466.36	1,268.17	1,044,865.47	26.54
<u>Transfers Out</u>						
06-12-99000 Transfer to CIP (Depreciati	<u>86,836</u>	<u>7,236.33</u>	<u>65,126.97</u>	<u>0.00</u>	<u>21,709.03</u>	<u>25.00</u>
TOTAL Transfers Out	86,836	7,236.33	65,126.97	0.00	21,709.03	25.00
TOTAL Municipal Authority	5,068,959	369,004.66	3,760,689.30	2,649.17	1,305,620.55	25.76
General Government						
=====						
Personnel Services						
Transfers Out						
TOTAL EXPENDITURES	5,068,959	369,004.66	3,760,689.30	2,649.17	1,305,620.55	25.76
REVENUE OVER/ (UNDER) EXPENDITURES	2 (	50,706.45)	207,217.97 (	2,649.17) (	204,566.80)	8,340.00-

13 -Municipal Authority - CIP  
 FINANCIAL SUMMARY

% OF YEAR COMPLETED: 75.00

	CURRENT BUDGET	CURRENT PERIOD	YEAR TO DATE ACTUAL	TOTAL ENCUMBERED	BUDGET BALANCE	% BUDGET REMAINING
<u>REVENUE SUMMARY</u>						
NHMA CIP - Revenues	<u>1,948,058</u>	<u>18,789.98</u>	<u>96,427.99</u>	<u>0.00</u>	<u>1,851,630.01</u>	<u>95.05</u>
TOTAL REVENUES	1,948,058	18,789.98	96,427.99	0.00	1,851,630.01	95.05
<u>EXPENDITURE SUMMARY</u>						
General Government	<u>1,948,058</u>	<u>0.00</u>	<u>227,419.97</u>	<u>43,765.00</u>	<u>1,676,873.03</u>	<u>86.08</u>
TOTAL EXPENDITURES	1,948,058	0.00	227,419.97	43,765.00	1,676,873.03	86.08
REVENUE OVER/ (UNDER) EXPENDITURES	0	18,789.98 (	130,991.98) (	43,765.00)	174,756.98	0.00

13 -Municipal Authority - CIP

% OF YEAR COMPLETED: 75.00

REVENUES	CURRENT BUDGET	CURRENT PERIOD	YEAR TO DATE ACTUAL	TOTAL ENCUMBERED	BUDGET BALANCE	% BUDGET REMAINING
<u>NHMA CIP - Revenues</u>						
=====						
<u>Intergovernmental</u>						
13-00-73850 Insurance Proceeds - etal	0	10,688.28	11,131.21	0.00	( 11,131.21)	0.00
TOTAL Intergovernmental	0	10,688.28	11,131.21	0.00	( 11,131.21)	0.00
<u>Investment Earnings</u>						
13-00-78500 Interest	0	865.37	20,169.81	0.00	( 20,169.81)	0.00
TOTAL Investment Earnings	0	865.37	20,169.81	0.00	( 20,169.81)	0.00
<u>Fund Balance Carryover</u>						
13-00-79800 Carryover	1,861,222	0.00	0.00	0.00	1,861,222.00	100.00
TOTAL Fund Balance Carryover	1,861,222	0.00	0.00	0.00	1,861,222.00	100.00
<u>Transfers</u>						
13-00-79920 Deprecation Transfers In	86,836	7,236.33	65,126.97	0.00	21,709.03	25.00
TOTAL Transfers	86,836	7,236.33	65,126.97	0.00	21,709.03	25.00
TOTAL NHMA CIP - Revenues	1,948,058	18,789.98	96,427.99	0.00	1,851,630.01	95.05
<hr/>						
TOTAL REVENUE	1,948,058	18,789.98	96,427.99	0.00	1,851,630.01	95.05

13 -Municipal Authority - CIP

% OF YEAR COMPLETED: 75.00

DEPARTMENTAL EXPENDITURES	CURRENT BUDGET	CURRENT PERIOD	YEAR TO DATE ACTUAL	TOTAL ENCUMBERED	BUDGET BALANCE	% BUDGET REMAINING
General Government =====						
Capital Projects						
13-12-88000 Capital Outlay	430,586	0.00	116,740.20	0.00	313,845.80	72.89
13-12-88100 Vehicles	236,143	0.00	86,027.17	43,765.00	106,350.83	45.04
13-12-88300 Capital Imp - Computers	24,951	0.00	0.00	0.00	24,951.00	100.00
13-12-88400 Capital Imp - Software	60,090	0.00	0.00	0.00	60,090.00	100.00
13-12-88500 Capital Imp - Equipment	135,494	0.00	24,652.60	0.00	110,841.40	81.81
13-12-88600 Capital Imp - Radios/Commun	6,777	0.00	0.00	0.00	6,777.00	100.00
13-12-89200 Capital Imp-Water Wells	944,017	0.00	0.00	0.00	944,017.00	100.00
13-12-89300 Capital Imp-Paint Water Tow	<u>110,000</u>	<u>0.00</u>	<u>0.00</u>	<u>0.00</u>	<u>110,000.00</u>	<u>100.00</u>
TOTAL Capital Projects	1,948,058	0.00	227,419.97	43,765.00	1,676,873.03	86.08
<hr/>						
TOTAL General Government	1,948,058	0.00	227,419.97	43,765.00	1,676,873.03	86.08
Information Systems =====						
Capital Projects						
<hr/>						
TOTAL EXPENDITURES	1,948,058	0.00	227,419.97	43,765.00	1,676,873.03	86.08
REVENUE OVER/ (UNDER) EXPENDITURES	0	18,789.98 (	130,991.98) (	43,765.00)	174,756.98	0.00

---

---

**INTEROFFICE MEMORANDUM**

---

---

**TO:** SHANE PATE; CITY MANAGER

**FROM:** RANDY LAWRENCE

**SUBJECT:** NHMA UTILITY TRAILER

**DATE:** 3/13/2024

The Public Works Department would like approval to purchase a Big Tex Tilt Deck Equipment Trailer replacing the one that was stolen. This will be purchased out of CIP Funds, not to exceed \$9,594.40 from Oklahoma Statewide Contract SW-0198 for NHMA 13-12-88500.

Thanks.

---

---

**INTEROFFICE MEMORANDUM**

---

---

**TO:** SHANE PATE.  
**FROM:** RANDY LAWRENCE  
**SUBJECT:** CNG TRUCK & GRAPPLE  
**DATE:** 3/14/2024

---

The Public Works Department would like permission to purchase a 2025 Freightliner M2-112 CNG truck from Oklahoma State Contract SW-035T, not to exceed \$164,000.00.

Also, a Petersen Grapple Body from Oklahoma State Contract SW-197 not to exceed \$131,187.00.

Total Truck & Grapple requested amount, \$295,187.00.

Thanks,

Public Works.



## Proposal for City of Nichols Hills

**Company Name:** Penske Commercial Vehicles, US, LLC / ATC Freightliner Group LLC,  
dba: Premier Truck Group

**Bidder Information:** Premier Truck Group / FEI: # 46-2758677

**Contact Person:** Jane Kirton, Account Manager @ 405-945-3577

**Physical Address:** 5301 I-40 West Oklahoma City, OK 73128

**Mailing Address:** PO Box 272430 Oklahoma City, OK 73137

**Specs Attached dated: March 5, 2024**

### **2025 Freightliner M2-112 ~ CNG ~ 2<sup>nd</sup> quarter build**

- Five years of extended towing coverage on warrantable failures
- Five years or 150,000 miles Cummins Engine
- Five years unlimited miles – Allison Transmission

**Total Chassis Price \$ 164,000.00**

  
**Jane Kirton**

Premier Truck Group

5301 I-40 West

Oklahoma City, OK 73128-1211

Cell: 405.973.8792

[jkirton@premiertruck.com](mailto:jkirton@premiertruck.com)

Prepared for:  
Jane Kirton  
STOCK OKLAHOMA CITY OK UISD  
5301 I 40 West  
Oklahoma City, OK 73128  
Phone: 405-942-8827

Prepared by:  
Jane Kirton  
PREMIER TRUCK GROUP OF  
OKLAHOMA CITY  
5301 I-40 WEST  
OKLAHOMA CITY, OK 73128  
Phone: 405-945-3577

## S P E C I F I C A T I O N   P R O P O S A L

Data Code	Description	Weight Front	Weight Rear
<b>Price Level</b>			
PRL-28M	M2 PRL-28M (EFF:MY25 ORDERS)		
<b>Data Version</b>			
DRL-032	SPECPRO21 DATA RELEASE VER 032		
<b>Vehicle Configuration</b>			
001-175	M2 112 PLUS CONVENTIONAL CHASSIS	8,244	6,026
004-225	2025 MODEL YEAR SPECIFIED		
002-004	SET BACK AXLE - TRUCK		
019-008	TRAILER TOWING PROVISION AT END OF FRAME WITH SAE J560, WITHOUT END OF FRAME AIR CONNECTIONS	15	15
003-001	LH PRIMARY STEERING LOCATION		
<b>General Service</b>			
AA1-002	TRUCK CONFIGURATION		
AA6-001	DOMICILED, USA 50 STATES (INCLUDING CALIFORNIA AND CARB OPT-IN STATES)		
99D-024	NON DIESEL VEHICLES ONLY - CARB CERTIFIED AND FOR INITIAL REGISTRATION IN 50 STATES, BUT NOT SUBJECT TO CARB CLEAN IDLE REQUIREMENTS		
AF2-998	NONE		
A85-011	CONSTRUCTION SERVICE		
A84-1GM	GOVERNMENT BUSINESS SEGMENT		
AA4-011	FIXED LOAD COMMODITY		
AA5-002	TERRAIN/DUTY: 100% (ALL) OF THE TIME, IN TRANSIT, IS SPENT ON PAVED ROADS		
AB1-008	MAXIMUM 8% EXPECTED GRADE		
AB5-001	SMOOTH CONCRETE OR ASPHALT PAVEMENT - MOST SEVERE IN-TRANSIT (BETWEEN SITES) ROAD SURFACE		

Application Version 11.9.606  
Data Version PRL-28M.032  
STOCK Cityof Nichols Hills CNG2025  
Grapple



Tender # CNG Petersen  
03/05/2024 5:00 PM  
Page 1 of 17

Prepared for:  
Jane Kirton  
STOCK OKLAHOMA CITY OK UISD  
5301 I 40 West  
Oklahoma City, OK 73128  
Phone: 405-942-8827

Prepared by:  
Jane Kirton  
PREMIER TRUCK GROUP OF  
OKLAHOMA CITY  
5301 I-40 WEST  
OKLAHOMA CITY, OK 73128  
Phone: 405-945-3577

Data Code	Description	Weight Front	Weight Rear
995-1AD	FREIGHTLINER LEVEL I WARRANTY		
A66-99D	EXPECTED FRONT AXLE(S) LOAD : 12000.0 lbs		
A68-99D	EXPECTED REAR DRIVE AXLE(S) LOAD : 21000.0 lbs		
A63-99D	EXPECTED GROSS VEHICLE WEIGHT CAPACITY : 33000.0 lbs		

### Truck Service

AA3-005	FLATBED/PLATFORM/STAKE BODY		
A89-99D	BRAKING-EXPECTED CAB TO BODY CLEARANCE : 27.0 in		
AF3-169	PETERSEN INDUSTRIES		
AF7-99D	EXPECTED BODY/PAYLOAD CG HEIGHT ABOVE FRAME "XX" INCHES : 32.0 in		

### Engine

101-3FM	CUM L9N 320 HP @ 2000 RPM, 2200 GOV, N- GAS, 1000 LB-FT @ 1300 RPM, HHD	-850	-70
---------	--	------	-----

### Electronic Parameters

79A-073	73 MPH ROAD SPEED LIMIT		
79B-002	CRUISE CONTROL SPEED LIMIT 2 MPH HIGHER THAN ROAD SPEED LIMIT		
79K-012	PTO MODE ENGINE RPM LIMIT - 1500 RPM		
79P-002	PTO RPM WITH CRUISE SET SWITCH - 700 RPM		
79Q-003	PTO RPM WITH CRUISE RESUME SWITCH - 800 RPM		
79S-001	PTO MODE CANCEL VEHICLE SPEED - 5 MPH		
79U-007	PTO GOVERNOR RAMP RATE - 250 RPM PER SECOND		
79W-001	ONE TEM PTO SPEED		
79X-012	PTO SPEED 1 SETTING - 1400 RPM		
80G-002	PTO MINIMUM RPM - 700		
80S-019	PTO 1, WITH SWITCH, TEM SUPPLIED REQUEST AND INTERLOCKS, WITH PTO CONNECTIONS, STATIONARY INTERLOCKS		
80T-019	PTO 2, WITH SWITCH, TEM SUPPLIED REQUEST AND INTERLOCKS, WITH PTO CONNECTIONS, STATIONARY INTERLOCKS		

### Engine Equipment

99C-124	EPA 2010 GHG 2024/CARB 2024 ULTRALOW NOX CONFIGURATION		
13E-001	STANDARD OIL PAN		
105-001	ENGINE MOUNTED OIL CHECK AND FILL		

Application Version 11.9.606  
Data Version PRL-28M.032  
STOCK City of Nichols Hills CNG2025  
Grapple



Tender # CNG Petersen  
03/05/2024 5:00 PM  
Page 2 of 17

Prepared for:  
Jane Kirton  
STOCK OKLAHOMA CITY OK UISD  
5301 I 40 West  
Oklahoma City, OK 73128  
Phone: 405-942-8827

Prepared by:  
Jane Kirton  
PREMIER TRUCK GROUP OF  
OKLAHOMA CITY  
5301 I-40 WEST  
OKLAHOMA CITY, OK 73128  
Phone: 405-945-3577

Data Code	Description	Weight Front	Weight Rear
014-099	SIDE OF HOOD AIR INTAKE WITH FIREWALL MOUNTED DONALDSON AIR CLEANER		
124-1DJ	DR 12V 160 AMP 36-SI BRUSHLESS QUADRAMOUNT PAD ALTERNATOR WITH REMOTE BATTERY VOLT SENSE	10	
292-235	(2) DTNA GENUINE, FLOODED STARTING, MIN 2000CCA, 370RC, THREADED STUD BATTERIES	-40	-10
290-017	BATTERY BOX FRAME MOUNTED		
281-001	STANDARD BATTERY JUMPERS		
282-003	SINGLE BATTERY BOX FRAME MOUNTED LH SIDE BACK OF CAB		
291-017	WIRE GROUND RETURN FOR BATTERY CABLES WITH ADDITIONAL FRAME GROUND RETURN		
289-001	NON-POLISHED BATTERY BOX COVER		
293-058	POSITIVE LOAD DISCONNECT WITH CAB MOUNTED CONTROL SWITCH MOUNTED OUTBOARD DRIVER SEAT	2	
295-029	POSITIVE AND NEGATIVE POSTS FOR JUMPSTART LOCATED ON FRAME NEXT TO STARTER	2	
306-015	PROGRESSIVE LOW VOLTAGE DISCONNECT AT 12.3 VOLTS FOR DESIGNATED CIRCUITS		
107-032	CUMMINS TURBOCHARGED 18.7 CFM AIR COMPRESSOR WITH INTERNAL SAFETY VALVE		
108-002	STANDARD MECHANICAL AIR COMPRESSOR GOVERNOR		
131-013	AIR COMPRESSOR DISCHARGE LINE		
152-041	ELECTRONIC ENGINE INTEGRAL SHUTDOWN PROTECTION SYSTEM		
128-998	NO RETARDER/ENGINE BRAKE		
016-013	SINGLE HORIZONTAL MUFFLER WITH HORIZONTAL TAILPIPE EXHAUST, RH MOUNTED	-160	-80
28F-010	ENGINE AFTERTREATMENT WIRING, OXYGEN SENSOR		
239-001	STANDARD EXHAUST SYSTEM LENGTH		
237-052	RH STANDARD HORIZONTAL TAILPIPE		
23U-998	NO DIESEL EXHAUST FLUID TANK	-25	-25
273-018	HORTON DRIVEMASTER ADVANTAGE ON/OFF FAN DRIVE		
276-001	AUTOMATIC FAN CONTROL WITHOUT DASH SWITCH, NON ENGINE MOUNTED		
110-017	CUMMINS SUPPLIED FLEETGUARD COALESCING FILTER (LOW PRESSURE) CNG		
118-008	COMBINATION FULL FLOW/BYPASS OIL FILTER		

Application Version 11.9.606  
Data Version PRL-28M.032  
STOCK Cityof Nichols Hills CNG2025  
Grapple



Tender # CNG Petersen  
03/05/2024 5:00 PM  
Page 3 of 17

Prepared for:  
Jane Kirton  
STOCK OKLAHOMA CITY OK UISD  
5301 I 40 West  
Oklahoma City, OK 73128  
Phone: 405-942-8827

Prepared by:  
Jane Kirton  
PREMIER TRUCK GROUP OF  
OKLAHOMA CITY  
5301 I-40 WEST  
OKLAHOMA CITY, OK 73128  
Phone: 405-945-3577

Data Code	Description	Weight Front	Weight Rear
266-017	1300 SQUARE INCH ALUMINUM RADIATOR	-20	
103-039	ANTIFREEZE TO -34F, OAT (NITRITE AND SILICATE FREE) EXTENDED LIFE COOLANT		
171-007	GATES BLUE STRIPE COOLANT HOSES OR EQUIVALENT		
172-001	CONSTANT TENSION HOSE CLAMPS FOR COOLANT HOSES		
138-011	PHILLIPS-TEMRO 1000 WATT/115 VOLT BLOCK HEATER	4	
140-053	BLACK PLASTIC ENGINE HEATER RECEPTACLE MOUNTED UNDER LH DOOR		
134-001	ALUMINUM FLYWHEEL HOUSING		
155-058	DELCO 12V 38MT HD STARTER WITH INTEGRATED MAGNETIC SWITCH	-10	

#### Transmission

342-582	ALLISON 3000 RDS AUTOMATIC TRANSMISSION WITH PTO PROVISION
---------	--

#### Transmission Equipment

343-325	ALLISON VOCATIONAL PACKAGE 180 - AVAILABLE ON 3000/4000 PRODUCT FAMILIES WITH VOCATIONAL MODEL RDS
84B-012	ALLISON VOCATIONAL RATING FOR ON/OFF HIGHWAY APPLICATIONS AVAILABLE WITH ALL PRODUCT FAMILIES
84C-023	PRIMARY MODE GEARS, LOWEST GEAR 1, START GEAR 1, HIGHEST GEAR 6, AVAILABLE FOR 3000/4000 PRODUCT FAMILIES ONLY
84D-023	SECONDARY MODE GEARS, LOWEST GEAR 1, START GEAR 1, HIGHEST GEAR 6, AVAILABLE FOR 3000/4000 PRODUCT FAMILIES ONLY
84E-000	PRIMARY SHIFT SCHEDULE RECOMMENDED BY DTNA AND ALLISON, THIS DEFINED BY ENGINE AND VOCATIONAL USAGE
84F-000	SECONDARY SHIFT SCHEDULE RECOMMENDED BY DTNA AND ALLISON, THIS DEFINED BY ENGINE AND VOCATIONAL USAGE
84G-000	PRIMARY SHIFT SPEED RECOMMENDED BY DTNA AND ALLISON, THIS DEFINED BY ENGINE AND VOCATIONAL USAGE
84H-000	SECONDARY SHIFT SPEED RECOMMENDED BY DTNA AND ALLISON, THIS DEFINED BY ENGINE AND VOCATIONAL USAGE
84J-000	ENGINE BRAKE RANGE PRESELECT RECOMMENDED BY DTNA AND ALLISON, THIS DEFINED BY ENGINE AND VOCATIONAL USAGE

Application Version 11.9.606  
Data Version PRL-28M.032  
STOCK City of Nichols Hills CNG2025  
Grapple



Tender # CNG Petersen  
03/05/2024 5:00 PM  
Page 4 of 17

Prepared for:  
Jane Kirton  
STOCK OKLAHOMA CITY OK UISD  
5301 I 40 West  
Oklahoma City, OK 73128  
Phone: 405-942-8827

Prepared by:  
Jane Kirton  
PREMIER TRUCK GROUP OF  
OKLAHOMA CITY  
5301 I-40 WEST  
OKLAHOMA CITY, OK 73128  
Phone: 405-945-3577

Data Code	Description	Weight Front	Weight Rear
84K-000	ENGINE BRAKE RANGE ALTERNATE PRESELECT RECOMMENDED BY DTNA AND ALLISON, THIS DEFINED BY ENGINE AND VOCATIONAL USAGE		
84N-200	FUEL SENSE 2.0 DISABLED - PERFORMANCE - TABLE BASED		
84U-000	DRIVER SWITCH INPUT - DEFAULT - NO SWITCHES		
353-076	QUICKFIT BODY LIGHTING CONNECTOR AT END OF FRAME, WITH BLUNTCUTS		
34C-011	ELECTRONIC TRANSMISSION WIRING TO CUSTOMER INTERFACE CONNECTOR		
362-824	(2) CUSTOMER INSTALLED CHELSEA 280 SERIES PTO'S		
363-011	PTO MOUNTING, LH AND RH SIDES OF MAIN TRANSMISSION		
341-018	MAGNETIC PLUGS, ENGINE DRAIN, TRANSMISSION DRAIN, AXLE(S) FILL AND DRAIN		
345-003	PUSH BUTTON ELECTRONIC SHIFT CONTROL, DASH MOUNTED		
97G-004	TRANSMISSION PROGNOSTICS - ENABLED 2013		
370-015	WATER TO OIL TRANSMISSION COOLER, IN RADIATOR END TANK	15	
346-003	TRANSMISSION OIL CHECK AND FILL WITH ELECTRONIC OIL LEVEL CHECK		
35T-001	SYNTHETIC TRANSMISSION FLUID (TES-295 COMPLIANT)		

### Front Axle and Equipment

400-1A6	DETROIT DA-F-12.0-3 12,000# FF1 71.5 KPI/3.74 DROP SINGLE FRONT AXLE		
402-020	MERITOR 15X4 Q+ CAM FRONT BRAKES		
403-002	NON-ASBESTOS FRONT BRAKE LINING		
419-001	CAST IRON OUTBOARD FRONT BRAKE DRUMS		
427-001	FRONT BRAKE DUST SHIELDS	5	
409-006	FRONT OIL SEALS		
408-001	VENTED FRONT HUB CAPS WITH WINDOW, CENTER AND SIDE PLUGS - OIL		
416-022	STANDARD SPINDLE NUTS FOR ALL AXLES		
405-002	MERITOR AUTOMATIC FRONT SLACK ADJUSTERS		
536-050	TRW THP-60 POWER STEERING		
539-003	POWER STEERING PUMP		

Application Version 11.9.606  
Data Version PRL-28M.032  
STOCK City of Nichols Hills CNG2025  
Grapple



Tender # CNG Petersen  
03/05/2024 5:00 PM  
Page 5 of 17

Prepared for:  
Jane Kirton  
STOCK OKLAHOMA CITY OK UISD  
5301 I 40 West  
Oklahoma City, OK 73128  
Phone: 405-942-8827

Prepared by:  
Jane Kirton  
PREMIER TRUCK GROUP OF  
OKLAHOMA CITY  
5301 I-40 WEST  
OKLAHOMA CITY, OK 73128  
Phone: 405-945-3577

Data Code	Description	Weight Front	Weight Rear
534-015	2 QUART SEE THROUGH POWER STEERING RESERVOIR		
40T-002	CURRENT AVAILABLE SYNTHETIC 75W-90 FRONT AXLE LUBE		
<b>Front Suspension</b>			
620-1F0	12,000# DUAL TAPERLEAF FRONT SUSPENSION	42	
619-005	MAINTENANCE FREE RUBBER BUSHINGS - FRONT SUSPENSION		
410-001	FRONT SHOCK ABSORBERS		
<b>Rear Axle and Equipment</b>			
420-009	CUMMINS-MERITOR RS-21-160 21,000# R-SERIES SINGLE REAR AXLE		-2,300
421-489	4.89 REAR AXLE RATIO		
424-001	IRON REAR AXLE CARRIER WITH STANDARD AXLE HOUSING		
386-074	MXL 176T MERITOR EXTENDED LUBE MAIN DRIVELINE WITH HALF ROUND YOKES	70	70
423-020	MERITOR 16.5X7 Q+ CAST SPIDER CAM REAR BRAKES, DOUBLE ANCHOR, FABRICATED SHOES		10
433-002	NON-ASBESTOS REAR BRAKE LINING		
434-012	BRAKE CAMS AND CHAMBERS ON REAR SIDE OF DRIVE AXLE(S)		
451-001	CAST IRON OUTBOARD REAR BRAKE DRUMS		-10
425-002	REAR BRAKE DUST SHIELDS		5
440-006	REAR OIL SEALS		
426-100	WABCO TRISTOP D LONGSTROKE 1-DRIVE AXLE SPRING PARKING CHAMBERS		-20
428-002	MERITOR AUTOMATIC REAR SLACK ADJUSTERS		
41T-002	CURRENT AVAILABLE SYNTHETIC 75W-90 REAR AXLE LUBE		
<b>Rear Suspension</b>			
622-001	23,000# FLAT LEAF SPRING REAR SUSPENSION WITH RADIUS ROD		50
621-001	SPRING SUSPENSION - NO AXLE SPACERS		
431-001	STANDARD AXLE SEATS IN AXLE CLAMP GROUP		
623-005	FORE/AFT CONTROL RODS		
<b>Pusher / Tag Equipment</b>			
429-998	NO PUSHER/TAG BRAKE DUST SHIELDS		

Application Version 11.9.606  
Data Version PRL-28M.032  
STOCK City of Nichols Hills CNG2025  
Grapple



Tender # CNG Petersen  
03/05/2024 5:00 PM  
Page 6 of 17

Prepared for:  
Jane Kirton  
STOCK OKLAHOMA CITY OK UISD  
5301 I 40 West  
Oklahoma City, OK 73128  
Phone: 405-942-8827

Prepared by:  
Jane Kirton  
PREMIER TRUCK GROUP OF  
OKLAHOMA CITY  
5301 I-40 WEST  
OKLAHOMA CITY, OK 73128  
Phone: 405-945-3577

Data Code	Description	Weight Front	Weight Rear
<b>Brake System</b>			
018-002	AIR BRAKE PACKAGE		
490-121	WABCO 4S/4M ABS WITH TRACTION CONTROL		
871-001	REINFORCED NYLON, FABRIC BRAID AND WIRE BRAID CHASSIS AIR LINES		
904-001	FIBER BRAID PARKING BRAKE HOSE		
412-001	STANDARD BRAKE SYSTEM VALVES		
46D-002	STANDARD AIR SYSTEM PRESSURE PROTECTION SYSTEM		
413-002	STD U.S. FRONT BRAKE VALVE		
432-003	RELAY VALVE WITH 5-8 PSI CRACK PRESSURE, NO REAR PROPORTIONING VALVE		
480-088	WABCO SYSTEM SAVER HP WITH INTEGRAL AIR GOVERNOR AND HEATER		
479-015	AIR DRYER FRAME MOUNTED		
460-001	STEEL AIR BRAKE RESERVOIRS		
477-008	BW DV-2 AUTO DRAIN VALVE WITH HEATER - WET TANK, PETCOCKS ALL OTHERS		
<b>Trailer Connections</b>			
481-998	NO TRAILER AIR HOSE		
476-998	NO AIR HOSE HANGER		
296-027	PRIMARY CONNECTOR/RECEPTACLE WIRED FOR COMBINATION STOP/TURN, CENTER PIN POWERED THROUGH IGNITION WITH STOP SIGNAL PREWIRE PACKAGE		
303-028	SAE J560 7-WAY PRIMARY TRAILER CABLE RECEPTACLE TEMPORARY TIED & COILED IN CHASSIS END OF FRAME WITH 6' ADDITIONAL; NO BRACKETS		
310-998	NO TRAILER ELECTRICAL CABLE		
<b>Wheelbase &amp; Frame</b>			
545-665	6650MM (262 INCH) WHEELBASE		
546-100	11/32X3-1/2X10-3/16 INCH STEEL FRAME (8.73MMX258.8MM/0.344X10.19 INCH) 120KSI	310	100
552-007	2450MM (96 INCH) REAR FRAME OVERHANG		
55W-009	FRAME OVERHANG RANGE: 91 INCH TO 100 INCH	-40	170
AC8-99D	CALC'D BACK OF CAB TO REAR SUSP C/L (CA) : 196.26 in		
AE8-99D	CALCULATED EFFECTIVE BACK OF CAB TO REAR SUSPENSION C/L (CA) : 169.26 in		
AE4-99D	CALC'D FRAME LENGTH - OVERALL : 388.43 in		

Application Version 11.9.606  
Data Version PRL-28M.032  
STOCK City of Nichols Hills CNG2025  
Grapple



Tender # CNG Petersen  
03/05/2024 5:00 PM  
Page 7 of 17

Prepared for:  
Jane Kirton  
STOCK OKLAHOMA CITY OK UISD  
5301 I 40 West  
Oklahoma City, OK 73128  
Phone: 405-942-8827

Prepared by:  
Jane Kirton  
PREMIER TRUCK GROUP OF  
OKLAHOMA CITY  
5301 I-40 WEST  
OKLAHOMA CITY, OK 73128  
Phone: 405-945-3577

Data Code	Description	Weight Front	Weight Rear	
FSS-0LH	CALCULATED FRAME SPACE LH SIDE : 162.64 in			
FSS-0RH	CALCULATED FRAME SPACE RH SIDE : 163.64 in			
553-001	SQUARE END OF FRAME			
550-001	FRONT CLOSING CROSSMEMBER			
559-001	STANDARD WEIGHT ENGINE CROSSMEMBER			
561-001	STANDARD CROSSMEMBER BACK OF TRANSMISSION			
562-001	STANDARD MIDSHIP #1 CROSSMEMBER(S)			
572-001	STANDARD REARMOST CROSSMEMBER			
565-001	STANDARD SUSPENSION CROSSMEMBER			
<b>Chassis Equipment</b>				
556-1AP	THREE-PIECE 14 INCH PAINTED STEEL BUMPER WITH COLLAPSIBLE ENDS	-10		
574-001	BUMPER MOUNTING FOR SINGLE LICENSE PLATE			
585-998	NO MUDFLAP BRACKETS			
590-998	NO REAR MUDFLAPS			
586-024	FENDER AND FRONT OF HOOD MOUNTED FRONT MUDFLAPS			
551-007	GRADE 8 THREADED HEX HEADED FRAME FASTENERS			
44Z-002	EXTERIOR HARNESES WRAPPED IN ABRASION TAPE			
<b>Fifth Wheel</b>				
578-998	NO FIFTH WHEEL			
<b>Fuel Tanks</b>				
N	204-998	NO LH FUEL TANK	-85	-20
	230-087	60 DIESEL GALLON EQUIVALENT (DGE) COMPRESSED NATURAL GAS (CNG) FUEL TANKS STACKED BACK OF CAB, 4X16 INCHES DIAMETER, 4TH GENERATION, TYPE 3 CYLINDERS	600	450
	231-008	STACKED TRANSVERSE MOUNTING BACK OF CAB FOR CNG TANKS WITH PAINTED SHIELDING	80	50
	664-001	PLAIN STEP FINISH		
	205-063	LH CNG NGV1 STANDARD FILL RECEPTACLE AND DUST CAPS WITH ADDITIONAL HIGH FLOW AND DEFUELER RECEPTACLES		



Prepared for:  
Jane Kirton  
STOCK OKLAHOMA CITY OK UISD  
5301 I 40 West  
Oklahoma City, OK 73128  
Phone: 405-942-8827

Prepared by:  
Jane Kirton  
PREMIER TRUCK GROUP OF  
OKLAHOMA CITY  
5301 I-40 WEST  
OKLAHOMA CITY, OK 73128  
Phone: 405-945-3577

Data Code	Description	Weight Front	Weight Rear
220-803	COOLANT HOSES ONLY ROUTED TO BACK OF CAB FOR CUSTOMER INSTALLED NATURAL GAS FUEL HEAT	5	
216-801	CNG, LNG, OR PROPANE INCOMPLETE FUEL LINES FOR TRANSPORT PURPOSES ONLY		
202-020	STAINLESS STEEL AND SYNTHETIC RUBBER FLEXIBLE FUEL LINES - NATURAL GAS SERVICE		
<b>Tires</b>			
093-2G7	BRIDGESTONE ECOPIA R268 295/75R22.5 14 PLY RADIAL FRONT TIRES	10	
094-1RY	BRIDGESTONE M726ELA 295/75R22.5 14 PLY RADIAL REAR TIRES		48
<b>Hubs</b>			
418-060	CONMET PRESET PLUS PREMIUM IRON FRONT HUBS		
450-060	CONMET PRESET PLUS PREMIUM IRON REAR HUBS		
<b>Wheels</b>			
502-753	MAXION WHEELS 91262 22.5X8.25 10-HUB PILOT 6.20 INSET 5-HAND STEEL DISC FRONT WHEELS	10	
505-753	MAXION WHEELS 91262 22.5X8.25 10-HUB PILOT 5-HAND STEEL DISC REAR WHEELS		20
496-011	FRONT WHEEL MOUNTING NUTS		
497-011	REAR WHEEL MOUNTING NUTS		
<b>Cab Exterior</b>			
829-072	112 INCH BBC FLAT ROOF ALUMINUM CONVENTIONAL CAB		
650-008	AIR CAB MOUNTING		
648-002	NONREMOVABLE BUGSCREEN MOUNTED BEHIND GRILLE		
678-018	LH AND RH EXTERIOR GRAB HANDLES WITH SINGLE RUBBER INSERT		
646-023	HOOD MOUNTED CHROMED PLASTIC GRILLE		
65X-003	CHROME HOOD MOUNTED AIR INTAKE GRILLE		
644-004	FIBERGLASS HOOD		
690-017	HOOD LINER, ADDED FIREWALL AND FLOOR HEAT INSULATION	5	
727-1AH	SINGLE 14 INCH ROUND POLISHED AIR HORN ROOF MOUNTED	4	
726-001	SINGLE ELECTRIC HORN		
728-001	SINGLE HORN SHIELD		

Application Version 11.9.606  
Data Version PRL-28M.032  
STOCK City of Nichols Hills CNG2025  
Grapple



Tender # CNG Petersen  
03/05/2024 5:00 PM  
Page 9 of 17

Prepared for:  
Jane Kirton  
STOCK OKLAHOMA CITY OK UISD  
5301 I 40 West  
Oklahoma City, OK 73128  
Phone: 405-942-8827

Prepared by:  
Jane Kirton  
PREMIER TRUCK GROUP OF  
OKLAHOMA CITY  
5301 I-40 WEST  
OKLAHOMA CITY, OK 73128  
Phone: 405-945-3577

Data Code	Description	Weight Front	Weight Rear
575-001	REAR LICENSE PLATE MOUNT END OF FRAME		
312-038	INTEGRAL HEADLIGHT/MARKER ASSEMBLY WITH CHROME BEZEL		
302-047	LED AERODYNAMIC MARKER LIGHTS		
311-003	DAYTIME RUNNING LIGHTS WITH ROCKER/TOGGLE MOMENTARY INTERRUPTER SWITCH		
294-042	FREIGHTLINER LED FLANGE MOUNTED STOP/TAIL/TURN LIGHTS WITH SEPARATE INCANDESCENT BACKUP LIGHTS		5
300-015	STANDARD FRONT TURN SIGNAL LAMPS		
744-1BC	DUAL WEST COAST BRIGHT FINISH HEATED MIRRORS WITH LH AND RH REMOTE		
797-001	DOOR MOUNTED MIRRORS		
796-001	102 INCH EQUIPMENT WIDTH		
743-204	LH AND RH 8 INCH BRIGHT FINISH CONVEX MIRRORS MOUNTED UNDER PRIMARY MIRRORS		
729-001	STANDARD SIDE/REAR REFLECTORS		
768-043	63X14 INCH TINTED REAR WINDOW		
661-003	TINTED DOOR GLASS LH AND RH WITH TINTED NON-OPERATING WING WINDOWS		
654-011	RH AND LH ELECTRIC POWERED WINDOWS		
663-013	1-PIECE SOLAR GREEN GLASS WINDSHIELD		
659-019	2 GALLON WINDSHIELD WASHER RESERVOIR WITHOUT FLUID LEVEL INDICATOR, FRAME MOUNTED		
647-001	WHITE WINTERFRONT	2	

**Cab Interior**

055-019	RUGGED TRIM PACKAGE		
707-107	GRAY & CARBON VINYL INTERIOR "RUGGED"		
70K-020	CARBON WITH PREMIUM GUNMETAL ACCENT (RUGGED)		
706-013	MOLDED PLASTIC DOOR PANEL		
708-013	MOLDED PLASTIC DOOR PANEL		
772-006	BLACK MATS WITH SINGLE INSULATION		
785-026	(1)DASH MOUNTED 12V POWER OUTLET, (1)DASH MOUNTED DUAL USB-C OUTLET		
691-001	FORWARD ROOF MOUNTED CONSOLE		
693-019	LH AND RH DOOR STORAGE POCKETS INTEGRATED INTO MOLDED DOOR PANELS		
738-021	DIGITAL ALARM CLOCK IN DRIVER DISPLAY		
742-007	(2) CUP HOLDERS LH AND RH DASH		

Application Version 11.9.606  
Data Version PRL-28M.032  
STOCK Cityof Nichols Hills CNG2025  
Grapple



Tender # CNG Petersen  
03/05/2024 5:00 PM  
Page 10 of 17

Prepared for:  
Jane Kirton  
STOCK OKLAHOMA CITY OK UISD  
5301 I 40 West  
Oklahoma City, OK 73128  
Phone: 405-942-8827

Prepared by:  
Jane Kirton  
PREMIER TRUCK GROUP OF  
OKLAHOMA CITY  
5301 I-40 WEST  
OKLAHOMA CITY, OK 73128  
Phone: 405-945-3577

Data Code	Description	Weight Front	Weight Rear
680-029	M2/SD DASH		
720-004	10 LB. FIRE EXTINGUISHER WITH MOUNTING BRACKET	20	
71T-002	METHANE DETECTION SYSTEM WITH (1) SENSOR IN CAB AND (1) SENSOR IN ENGINE COMPARTMENT	10	
714-001	FIRST AID KIT	2	
700-002	HEATER, DEFROSTER AND AIR CONDITIONER		
701-001	STANDARD HVAC DUCTING		
703-005	MAIN HVAC CONTROLS WITH RECIRCULATION SWITCH		
170-015	STANDARD HEATER PLUMBING		
130-041	VALEO HEAVY DUTY A/C REFRIGERANT COMPRESSOR		
702-002	BINARY CONTROL, R-134A		
739-034	PREMIUM INSULATION		
285-013	SOLID-STATE CIRCUIT PROTECTION AND FUSES		
280-007	12V NEGATIVE GROUND ELECTRICAL SYSTEM		
324-1B2	PREMIUM LED CAB LIGHTING		
787-998	NO SECURITY DEVICE		
657-001	DOOR LOCKS AND IGNITION SWITCH KEYED THE SAME		
78G-004	KEY QUANTITY OF 4		
655-005	LH AND RH ELECTRIC DOOR LOCKS		
722-002	TRIANGULAR REFLECTORS WITHOUT FLARES	10	
756-338	BASIC ISRINGHAUSEN HIGH BACK AIR SUSPENSION DRIVERS SEAT WITH MECHANICAL LUMBAR AND INTEGRATED CUSHION EXTENSION	30	
760-344	2 MAN TOOL BOX MID BACK NON SUSPENSION PASSENGER SEAT WITH HEADRESTS, SEATS INC.	20	
759-007	DUAL DRIVER SEAT ARMRESTS, NO PASSENGER SEAT ARMRESTS	4	
711-004	LH AND RH INTEGRAL DOOR PANEL ARMRESTS		
758-1AK	BLACK VINYL DRIVER SEAT COVER		
761-1AK	BLACK VINYL PASSENGER SEAT COVER		
763-102	HIGH VISIBILITY ORANGE SEAT BELTS		
532-002	ADJUSTABLE TILT AND TELESCOPING STEERING COLUMN		
540-044	4-SPOKE 18 INCH (450MM) BLACK STEERING WHEEL WITH SWITCHES		

Application Version 11.9.606  
Data Version PRL-28M.032  
STOCK City of Nichols Hills CNG2025  
Grapple



Tender # CNG Petersen  
03/05/2024 5:00 PM  
Page 11 of 17

Prepared for:  
Jane Kirton  
STOCK OKLAHOMA CITY OK UISD  
5301 I 40 West  
Oklahoma City, OK 73128  
Phone: 405-942-8827

Prepared by:  
Jane Kirton  
PREMIER TRUCK GROUP OF  
OKLAHOMA CITY  
5301 I-40 WEST  
OKLAHOMA CITY, OK 73128  
Phone: 405-945-3577

Data Code	Description	Weight Front	Weight Rear
765-002	DRIVER AND PASSENGER INTERIOR SUN VISORS		
<b>Instruments &amp; Controls</b>			
* 4CH-004	4 EXTRA PROGRAMMABLE SWITCHES/INDICATORS \$C1B0000ZZ,C1C0000ZZ,C1D0000ZZ,C1E0000ZZ		
106-002	ELECTRONIC ACCELERATOR CONTROL		
734-023	CONFIGURABLE LOWER PANEL WITH INTEGRATED UPPER STORAGE		
87L-001	ENGINE REMOTE INTERFACE WITH PARK BRAKE INTERLOCK		
870-002	BRIGHT ARGENT FINISH GAUGE BEZELS		
486-001	LOW AIR PRESSURE INDICATOR LIGHT AND AUDIBLE ALARM		
840-001	DUAL NEEDLE PRIMARY AND SECONDARY AIR PRESSURE GAUGE		
198-025	INTAKE MOUNTED AIR RESTRICTION INDICATOR WITHOUT GRADUATIONS		
721-001	97 DB BACKUP ALARM		3
149-015	ELECTRONIC CRUISE CONTROL WITH CONTROLS ON STEERING WHEEL SPOKES		
156-007	KEY OPERATED IGNITION SWITCH AND INTEGRAL START POSITION; 4 POSITION OFF/RUN/START/ACCESSORY		
811-044	PREMIUM INSTRUMENT CLUSTER WITH 5.0 INCH TFT COLOR DISPLAY		
81B-003	DIGITAL PANEL LAMP DIMMER SWITCH IN DRIVER DISPLAY		
160-038	HEAVY DUTY ONBOARD DIAGNOSTICS INTERFACE CONNECTOR LOCATED BELOW LH DASH		
844-027	AGILITY BLUE IQ FUEL GAUGE - 4TH GEN PROCAB SYSTEMS FMM CONTROLLERS		
148-072	ENGINE REMOTE INTERFACE WITH ONE OR MORE SET SPEEDS		
48H-002	QUICKFIT POWERTRAIN INTERFACE CONNECTOR LOCATED BETWEEN SEATS WITH BLUNTCUTS		
4C0-998	NO ADDITIONAL EXTRA SWITCH ACCUATORS		
48C-002	QUICKFIT PROGRAMMABLE INTERFACE CONNECTOR(S) BETWEEN SEATS WITH BLUNTCUTS		
163-014	ENGINE REMOTE INTERFACE CONNECTOR AT POWERTRAIN INTERFACE CONNECTOR		



Prepared for:  
Jane Kirton  
STOCK OKLAHOMA CITY OK UISD  
5301 I 40 West  
Oklahoma City, OK 73128  
Phone: 405-942-8827

Prepared by:  
Jane Kirton  
PREMIER TRUCK GROUP OF  
OKLAHOMA CITY  
5301 I-40 WEST  
OKLAHOMA CITY, OK 73128  
Phone: 405-945-3577

Data Code	Description	Weight Front	Weight Rear
856-001	ELECTRICAL ENGINE COOLANT TEMPERATURE GAUGE		
864-001	2 INCH TRANSMISSION OIL TEMPERATURE GAUGE		
867-004	ELECTRONIC OUTSIDE TEMPERATURE SENSOR DISPLAY IN DRIVER MESSAGE CENTER		
830-017	ENGINE AND TRIP HOUR METERS INTEGRAL WITHIN DRIVER DISPLAY		
372-123	PTO CONTROLS FOR ENHANCED VEHICLE ELECTRIC/ELECTRONIC ARCHITECTURE		
736-998	NO OBSTACLE DETECTION SYSTEM		
72J-998	NO DR ASSIST SYSTEM		
49B-998	NO VEHICLE STABILITY ADVISOR OR CONTROL		
73B-998	NO LANE DEPARTURE WARNING SYSTEM		
852-002	ELECTRIC ENGINE OIL PRESSURE GAUGE		
35M-011	QUICKFIT PROGRAMMABLE INTERFACE MODULE + (4) 20 AMP FUSED RELAYS	10	
746-137	AM/FM/WB WORLD TUNER RADIO WITH BLUETOOTH, USB AND AUXILIARY INPUTS, J1939		
747-001	DASH MOUNTED RADIO		
750-002	(2) RADIO SPEAKERS IN CAB		
753-001	AM/FM ANTENNA MOUNTED ON FORWARD LH ROOF		
74D-006	STANDARD RADIO WIRING WITH STEERING WHEEL CONTROLS		
810-027	ELECTRONIC MPH SPEEDOMETER WITH SECONDARY KPH SCALE, WITHOUT ODOMETER		
817-001	STANDARD VEHICLE SPEED SENSOR		
812-001	ELECTRONIC 3000 RPM TACHOMETER		
813-1C8	DETROIT CONNECT PLATFORM HARDWARE		
8D1-313	3 YEARS DAIMLER CONNECTIVITY BASE PACKAGE ON (FEATURES VARY BY MODEL) POWERED BY DETROIT CONNECT ON CUMMINS ENGINES		
6TS-008	(2) TMC RP1226 ACCESSORY CONNECTORS: (1) LOCATED BEHIND PASSENGER SIDE REMOVABLE DASH PANEL (1) CENTER OF OVERHEAD CONSOLE		
162-002	IGNITION SWITCH CONTROLLED ENGINE STOP		
329-133	FOUR EXTRA HARDWIRED SWITCHES IN DASH, ROUTE TO BETWEEN SEATS, BLUNTCUT		

Application Version 11.9.606  
Data Version PRL-28M.032  
STOCK Cityof Nichols Hills CNG2025  
Grapple



Tender # CNG Petersen  
03/05/2024 5:00 PM  
Page 13 of 17

Prepared for:  
Jane Kirton  
STOCK OKLAHOMA CITY OK UISD  
5301 I 40 West  
Oklahoma City, OK 73128  
Phone: 405-942-8827

Prepared by:  
Jane Kirton  
PREMIER TRUCK GROUP OF  
OKLAHOMA CITY  
5301 I-40 WEST  
OKLAHOMA CITY, OK 73128  
Phone: 405-945-3577

Data Code	Description	Weight Front	Weight Rear
4C1-025	HARDWIRE SWITCH #1, ON/OFF LATCHING, 20 AMPS IGNITION POWER		
4C2-025	HARDWIRE SWITCH #2, ON/OFF LATCHING, 20 AMPS IGNITION POWER		
4C3-005	HARDWIRE SWITCH #3, ON/OFF MOMENTARY, 20 AMPS IGNITION POWER		
4C4-016	HARDWIRE SWITCH #4, ON/OFF LATCHING, 20 AMPS IGNITION POWER		
264-030	(1) OVERHEAD MOUNTED LANYARD CONTROL FOR DRIVER AIR HORN		
883-998	NO TRAILER HAND CONTROL BRAKE VALVE		
836-015	DIGITAL VOLTAGE DISPLAY INTEGRAL WITH DRIVER DISPLAY		
660-008	SINGLE ELECTRIC WINDSHIELD WIPER MOTOR WITH DELAY		
304-030	ROTARY HEADLAMP SWITCH, MARKER LIGHTS/HEADLIGHTS SWITCH WITH PULL OUT FOR OPTIONAL FOG/ROAD LAMPS		
882-009	ONE VALVE PARKING BRAKE SYSTEM WITH WARNING INDICATOR		
299-020	SELF CANCELING TURN SIGNAL SWITCH WITH DIMMER, HEADLAMP FLASH, WASH/WIPE/INTERMITTENT		
298-046	INTEGRAL ELECTRONIC TURN SIGNAL FLASHER WITH 40 AMP (20 AMP PER SIDE) TRAILER LAMP CAPACITY		
869-800	HOLE IN DASH FOR CUSTOMER FURNISHED 2 INCH GAUGE		

**Design**

065-000 PAINT: ONE SOLID COLOR

**Color**

980-5F6 CAB COLOR A: L0006EY WHITE ELITE EY  
986-020 BLACK, HIGH SOLIDS POLYURETHANE CHASSIS PAINT  
98K-5F6 PAINT-FUEL CABINET: L0006EY WHITE ELITE EY  
962-972 POWDER WHITE (N0006EA) FRONT WHEELS/RIMS (PKWHT21, TKWHT21, W, TW)  
966-972 POWDER WHITE (N0006EA) REAR WHEELS/RIMS (PKWHT21, TKWHT21, W, TW)  
964-6Z7 BUMPER PAINT: FP24812 ARGENT SILVER DUPONT FLEX  
969-998 NO CAB/BODY EXTERIOR DECALS  
963-003 STANDARD E COAT/UNDERCOATING

Application Version 11.9.606  
Data Version PRL-28M.032  
STOCK City of Nichols Hills CNG2025  
Grapple



Tender # CNG Petersen  
03/05/2024 5:00 PM  
Page 14 of 17

Prepared for:  
 Jane Kirton  
 STOCK OKLAHOMA CITY OK UISD  
 5301 I 40 West  
 Oklahoma City, OK 73128  
 Phone: 405-942-8827

Prepared by:  
 Jane Kirton  
 PREMIER TRUCK GROUP OF  
 OKLAHOMA CITY  
 5301 I-40 WEST  
 OKLAHOMA CITY, OK 73128  
 Phone: 405-945-3577

Data Code	Description	Weight Front	Weight Rear
<b>Certification / Compliance</b>			
996-001	U.S. FMVSS CERTIFICATION, EXCEPT SALES CABS AND GLIDER KITS		
<b>Sales Programs</b>			
N	PMY-3G2 BUSINESS QUOTE SALES PROGRAM		

**TOTAL VEHICLE SUMMARY**

<b>Weight Summary</b>			
	Weight Front	Weight Rear	Total Weight
Factory Weight <sup>+</sup>	8301 lbs	4487 lbs	12788 lbs
Total Weight <sup>+</sup>	8301 lbs	4487 lbs	12788 lbs

<b>Extended Warranty</b>	
WAI-5J4	CUM EPA17 L9N: GE1 HWY 5 YEARS/150,000 MILES/241,500 KM EXT WARR. FEX APPLIES
WAK-251	ALLISON 3000 RDS SERIES TRANSMISSION EXTEND WARRANTY, 5 YEARS/UNLIMITED MILES FEX
WAG-078	TOWING: 5 YEARS/UNLIMITED MILES/KM EXTENDED TOWING COVERAGE \$750 CAP FEX APPLIES

(+) Weights shown are estimates only.  
 If weight is critical, contact Customer Application Engineering.

(\*\*\*) All cost increases for major components (Engines, Transmissions, Axles, Front and Rear Tires) and government mandated requirements, tariffs, and raw material surcharges will be passed through and added to factory invoices.

Application Version 11.9.606  
 Data Version PRL-28M.032  
 STOCK City of Nichols Hills CNG2025  
 Grapple



Tender # CNG Petersen  
 03/05/2024 5:00 PM  
 Page 15 of 17

Prepared for:  
 Jane Kirton  
 STOCK OKLAHOMA CITY OK UISD  
 5301 I 40 West  
 Oklahoma City, OK 73128  
 Phone: 405-942-8827

Prepared by:  
 Jane Kirton  
 PREMIER TRUCK GROUP OF  
 OKLAHOMA CITY  
 5301 I-40 WEST  
 OKLAHOMA CITY, OK 73128  
 Phone: 405-945-3577

**D I M E N S I O N S**

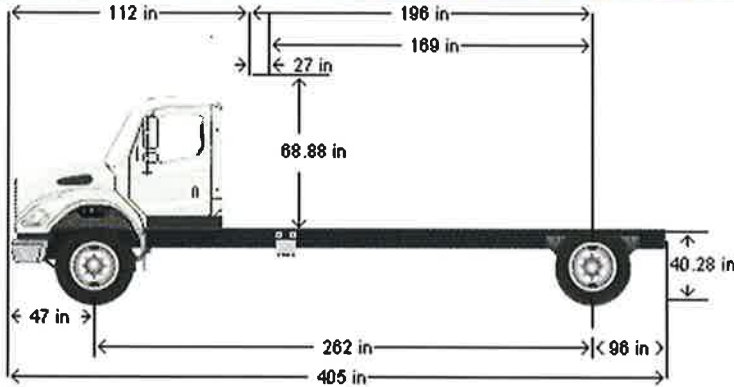

**VEHICLE SPECIFICATIONS SUMMARY - DIMENSIONS**

Model.....	M2112
Wheelbase (545).....	6650MM (262 INCH) WHEELBASE
Rear Frame Overhang (552).....	2450MM (96 INCH) REAR FRAME OVERHANG
Fifth Wheel (578).....	NO FIFTH WHEEL
Mounting Location (577).....	NO FIFTH WHEEL LOCATION
Maximum Forward Position (in).....	0
Maximum Rearward Position (in).....	0
Amount of Slide Travel (in).....	0
Slide Increment (in).....	0
Desired Slide Position (in).....	0.0
Cab Size (829).....	112 INCH BBC FLAT ROOF ALUMINUM CONVENTIONAL CAB
Sleeper (682).....	NO SLEEPER BOX/SLEEPER CAB
Exhaust System (016).....	SINGLE HORIZONTAL MUFFLER WITH HORIZONTAL TAILPIPE EXHAUST, RH MOUNTED



Prepared for:  
Jane Kirton  
STOCK OKLAHOMA CITY OK UISD  
5301 I 40 West  
Oklahoma City, OK 73128  
Phone: 405-942-8827

Prepared by:  
Jane Kirton  
PREMIER TRUCK GROUP OF  
OKLAHOMA CITY  
5301 I-40 WEST  
OKLAHOMA CITY, OK 73128  
Phone: 405-945-3577

**TABLE SUMMARY - DIMENSIONS**

Dimensions	Inches
Bumper to Back of Cab (BBC)	112.4
Bumper to Centerline of Front Axle (BA)	46.9
Front Axle to Back of Cab (AC)	65.6
Min. Cab to Body Clearance (CB)	27.0
Back of Cab to Centerline of Rear Axle(s) (CA)	196.3
Effective Back of Cab to Centerline of Rear Axle(s) (Effective CA)	169.3
Back of Cab Protrusions (Exhaust/Intake) (CP)	2.0
Back of Cab Protrusions (Side Extenders/Trim Tab) (CP)	0.0
Back of Cab Protrusions (CNG Tank)	25.6
Back of Cab Clearance (CL)	27.0
Back of Cab to End of Frame	292.8
Cab Height (CH)	68.9
Wheelbase (WB)	261.8
Frame Overhang (OH)	96.5
Overall Frame Length	388.4
Overall Length (OAL)	405.2
Rear Axle Spacing	0.0
Unladen Frame Height at Centerline of Rear Axle	40.3

Performance calculations are estimates only. If performance calculations are critical, please contact Customer Application Engineering.



Quote



Quote No 20232333 Quote Date 3/11/2024 Page 1



**J&R EQUIPMENT**  
ENVIRONMENTAL TRUCK SALES

**8800 SW 8TH ST.**  
**Oklahoma City, OK 73128**

**WWW.JANDREQUIPMENT.COM**

END USER: Nichols Hill, City of (OK)

Customer No 1451 Slspn Austin Bruner

Loc PPD/COL LW Ship via DRIVE AWAY Ship Date A.S.A.P.

Delivery Date: 90-120 days after CHAS

Qty Ordered UOM Item No Extended price

1.00 EA LOADER 71,720.00

AS CONFIGURED BELOW  
\*\*CNG SYSTEM TO BE MOUNTED BEHIND CAB\*\*

Feature/Kit Components- LOADER

1.00	EA	0.TL3	1.00	64,983.00
		MODEL TL3 BASE LOADER		
1.00	EA	03.11SAI	1.00	0.00
		HEAVY DUTY SWING MOTOR		
1.00	EA	03.12 STD HT PED	1.00	0.00
		STANDARD HEIGHT PEDESTAL		
1.00	EA	01.11MQCA	1.00	3,253.00
		QUADSTICK MECH CONTROLS (UPGRADE for TL)		
1.00	EA	01.24	1.00	478.00
		GRATING HEAT SHIELD (FOR DUAL CONTROLS ONLY)		
1.00	EA	10.16 HDHI	1.00	593.00
		HDHI OUTRIGGER STROBE		
1.00	EA	07.10SB60	1.00	0.00
		STANDARD BUCKET 60"		
1.00	EA	10.04 BUWL	1.00	0.00
		BOOM-UP WARNING LIGHT/AUDIBLE ALARM		
1.00	EA	12.05 HG	1.00	447.00
		HOSE GUARDS- HEAD & VALVE BANK		
1.00	EA	12.36 HD	1.00	0.00
		HD CONTROL BOX THROTTLE ENGINE KILL & HORN		
1.00	EA	12.02 TP	1.00	0.00
		TANDEM PUMP IN LIEU OF SINGLE 18 GMP		
1.00	EA	12.22 ICCNG	1.00	1,966.00
		INSTALLATION CHARGE ON ANY CNG/LNG CHASSIS		
1.00	EA	11.02	1.00	0.00
		LOADER SINGLE COLOR (ENAMEL) AS DEFINED BELOW		

1.00 EA 8.0 DUMP BODY 45,040.00

AS CONFIGURED BELOW

Feature/Kit Components- 8.0 DUMP BODY

1.00	EA	8.28 1828-HDX	1.00	38,782.00
		MODEL HDX-1828 HARDOX BODY 1/8" SIDES, 3/16" FLOOR		
1.00	EA	8.32 CW	1.00	887.00
		CONTINUOUS WELDS UPGRADE		



**Bill To**

J & R EQUIPMENT L.L.C.  
8800 SW 8TH STREET  
OKLAHOMA CITY, OK 73128  
US

**Ship to**

J & R EQUIPMENT L.L.C.  
8800 SW 8TH STREET  
OKLAHOMA CITY, OK  
US

END USER: Nichols Hill, City of (OK)

Customer No	Slpsn	Payment terms	Ship Date	Delivery Date:	Extended price
1451	Austin Bruner		A.S.A.P.	90-120 days after CHAS	
Loc	PPD/COL	Ship via	Ship Date	Delivery Date:	Extended price
LW		DRIVE AWAY			
Qty Ordered	UOM	Item No			

		FOR 18' TO 20' BODIES			
1.00	EA	8.36 PISWLCD PI SELF-WINDING LOAD COVERING DEVICE (ADD-ON)	1.00		1,379.00
1.00	EA	8.72 OPRD SINGLE PIECE REAR DOOR (REPLACES STND BARN DOORS)	1.00		1,441.00
1.00	EA	8.47 WL-BW WIRE LOOM FOR BODY WIRING	1.00		0.00
1.00	EA	10.09 LED LED TYPE BODY LIGHTS, 15 EA.	1.00		0.00
1.00	EA	10.10 LED FLASH AMBER LED FLASHERS IN REAR CORNER POST	1.00		437.00
1.00	EA	8.77ANSI ANSI Z245 PACKAGE	1.00		0.00
1.00	EA	8.76 RCMTL REAR CAMERA MOUNTED IN REAR MARKER LIGHT-TV-550	1.00		1,804.00
1.00	EA	11.03 ADD, LOADER & BODY SAME COLOR (PI COLOR NOT BLACK OR ORANGE)	1.00		310.00

Price per above specs \$116,760.00

SW 197 price plus 5% \$5,837.00

Freight \$8,590.00

**Total delivered with unlimited training \$131,187.00**

\*\*PAINT LOADER AND BODY P.I. WHITE\*\*  
\*\*CNG SYSTEM MOUNTED BEHIND CAB\*\*  
Rodney Womack/405-780-8111

Signature

Date

THE QUOTE TOTAL MAY NOT REFLECT MISCELLANEOUS CHARGES, FREIGHT OR SALES TAX